

# CANTY

## PROCESS TECHNOLOGY

### GLASS WETTED FUSEVIEW™ SIGHT GLASS

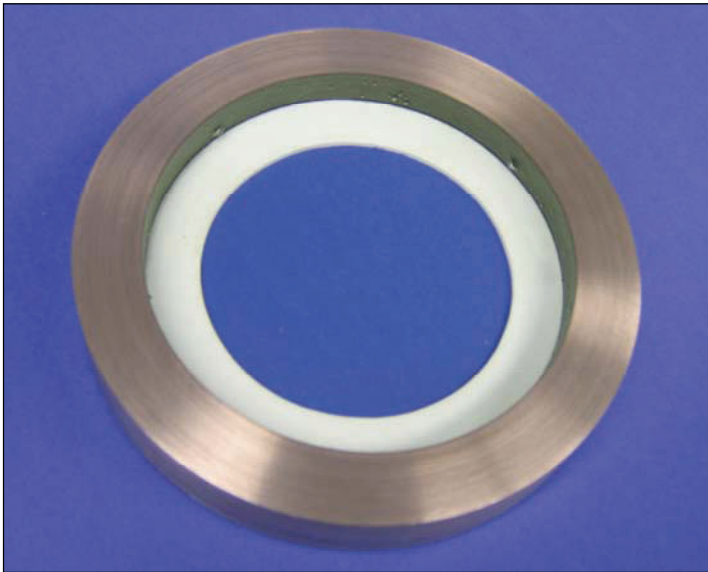

#### UNIQUE DESIGN

The glass-wetted Fuseview™ is designed for use on glass lined reactors and other tanks where only glass is allowed in contact with the product.

#### THE CANTY ADVANTAGE

J.M. Canty Fuseview™ sight glasses have been engineered to meet all your process and safety needs. Glass wetted Fuseviews™ are a fused sight glass providing one-piece construction with no additional gaskets or torquing required. All Canty Glass wetted Fuseviews™ were designed and tested to ensure the safest product available. Canty can provide certification of material and testing if required, typical of ASME code requirements for process vessels.

#### UNMATCHED SAFETY, RELIABILITY

All Canty sight glasses feature the Fuseview™ window. Our unique fused glass windows far exceed all conventional tempered glass windows in safety and performance. By fusing glass to metal, a high pressure, high safety, hermetic seal is formed. The fused glass technology ensures safety with every Fuseview™. What's more, our windows can easily be removed for cleaning. Canty windows do not have to be discarded, as do traditional tempered glass windows. Canty fused glass windows can be re-used again and again.

#### SPECIFICATIONS

- Wetted material: Boro Plus™ glass
- Ring Material: Alloy C, Hastelloy® C276 or equal
- Retaining Flange: CS, SS, User supplied
- Standard Rating: 150 PSI @ 450°F  
10 bar @ 204°C

#### FEATURES

- Extremely high strength due to radial compression on the hermetically sealed glass.
- High impact strength and thermal shock resistance due to prestressing.
- Certification on material and pressure rating is available, typical of ASME code requirements.
- Canty Fuseviews™ may be removed for cleaning and inspection. This is not allowed with ordinary glass, due to residual stresses incurred at bolt-up.
- No loss of glass temper over time!
- Perfect for Glass Wetted, C2000, and Exotic Material Reactors

#### CANTY FUSEVIEW™ VS METALGLASS

- Largest view in the Industry. When you order a 4" window you get a 4" view!
- Boro Plus™ fused glass is superior to other glass with ideal optical and fusing properties. It readily fuses to steel making a one piece hermitically sealed window capable of high pressures and temperatures.
- Ideal properties of metal and glass provides true fusion of glass to metal. This provides a stronger safer fuse that will not crack during installation or operation like borosilicate and duplex stainless steels.
- Superior impact, thermal shock, and pressure resistance from the use of optimum materials and the proper fusing process during manufacturing.

#### OPTIONS

- Lighting - Flex bundle light eliminates a second nozzle
- Canty Jet spray ring for cleaning or cooling, available in Teflon or any compatible metal
- Dual fused glass for high temperature applications

**CANTY**

JM Canty Inc | Buffalo, NY USA  
JM Canty Intl Ltd | Dublin, Ireland

Ph: (716) 625 4227  
Ph: + 353 (01) 882 9621

Fax: (716) 625 4228  
Fax: +353 (01) 882 9622

[www.jmcanty.com](http://www.jmcanty.com)

Document P/N: TA10149-1 Rev 5

All registered trademarks are the property of their respective owners.

## GLASS WETTED FUSEVIEW™ SPECIFICATIONS

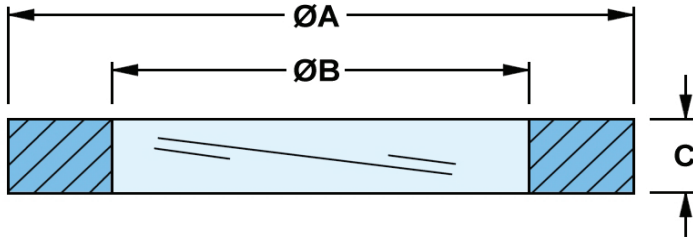

ANSI Size	Ø A	Ø B	C
1"	2.58"	1.9"	.75"
1.5"	3.25"	2.5"	.75"
2"	4.00"	3.0"	.75"
3"	5.25"	4.0"	.75"
4"	6.75"	5.19"	.75"
6"	8.63"	7.13"	.90"
8"	10.88"	9.13"	1.18"

DIN Size	Ø A	Ø B	C
25mm	69.9mm	50.8mm	19mm
40mm	88.9mm	63.5mm	19mm
50mm	101.6mm	76.2mm	19mm
65mm	123.8mm	88.9mm	19mm
80mm	139.7mm	108.0mm	19mm
100mm	161.9mm	131.8mm	19mm
150mm	218.2mm	181.0mm	23mm
200mm	273.1mm	231.8mm	30mm

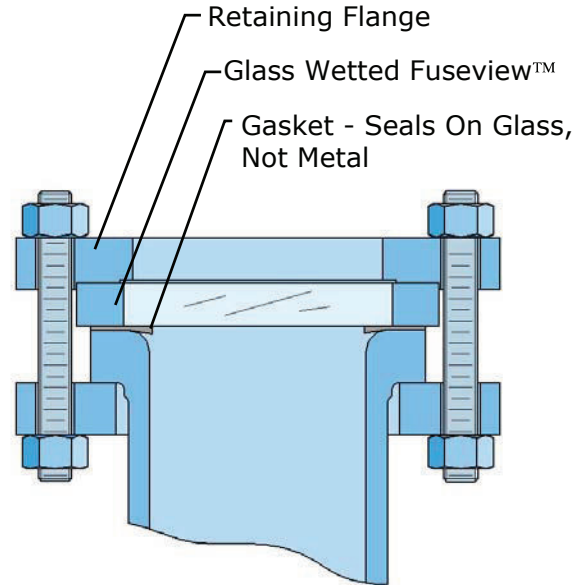

To make a Fuseview™, you bring the glass up to its molten point where it flows to the wall of the metal. At that point the glass fuses or bonds to the metal. Then we slowly cool the Fuseview™ until the glass solidifies. The metal has a higher coefficient of expansion than the glass and the metal compresses on the glass, This prestresses the glass and puts it under radial compression. Glass is extremely strong in compression ( not tension or shear). When the Fuseview™ is pressurized the glass bends and relieves the compression, avoiding tension. This is the same concept used in concrete - it is prestressed in compression to take tension.

### Ordering Information

HOW TO ORDER: Select the appropriate symbols and build a part number as shown:

**EXAMPLE:**

S 8      1 0      A 0

PRESSURE:  
A = 150 #  
1 = 10 BAR

SIZE:  
E = 1"                      6 = 25 mm  
F = 1.5"                    7 = 40 mm  
A = 2"                        8 = 65 mm  
B = 3"                        2 = 80 mm  
C = 4"                        3 = 100 mm  
D = 6"                        4 = 150 mm  
G = 8"                        5 = 200 mm

RETAINER MATERIAL (non-wetted):  
0 = No retainer  
1 = Carbon Steel  
2 = 316L Stainless Steel

FUSEVIEW™ RING MATERIAL (non-wetted):  
B - 316L Stainless Steel\*  
C - Hastelloy® C (standard 2"-8" & 50mm - 200mm)

\* Cauty reserves the right to upgrade to Hastelloy® C-family of alloys or equal at their own cost.