

CANTY

PROCESS TECHNOLOGY

FUSEVIEW™ TRI-CLAMP® SIGHT GLASS



THE CANTY ADVANTAGE

J.M. Canty Fuseview™ sight glasses have been engineered to meet all your process and safety needs. Fuseview™ Tri-clamps® are a fused sight glass providing one-piece construction with no additional gaskets or torquing required. All standard Tri-clamp® Fuseviews™ feature Factory Mutual approval and were designed and tested to ensure the safest product available. Canty can provide certification of material and testing if required, typical of ASME code requirements for process

UNMATCHED SAFETY, RELIABILITY

All Canty sight glasses feature the Fuseview™ window. Our unique fused glass windows far exceed all conventional tempered glass windows in safety and performance. By fusing glass to metal, a high pressure, high safety, hermetic seal is formed. The fused glass Technology ensures safety with every Fuseview™. What's more, our windows can easily be removed for cleaning. Canty windows do not have to be discarded, as do traditional tempered glass windows. Canty fused glass windows can be re-used again and again.

OPTIONS

- Lighting - Flex bundle light available to eliminate the need for a second nozzle
- Jet spray ring - integral or two piece spray ring available for cleaning glass
- Flush style available for flat mounting with no crevice or dead space

FEATURES

- All standard models are FM approved!
- Stainless Steel, Alloy C, Hastelloy®C276 or equal, or Hastelloy® C-22® or equal one piece construction
- Pressure rating to 150 PSI [10 bar], actual rating is dictated by clamp and ferrule selection
- Standard temperatures to 450°F [232°C]
- One piece sanitary construction
- Connects to standard Tri-clamp® connection
- Special sizes available per drawing request

ADVANTAGES OF THE FUSEVIEW™

- Standard models feature FM approval!
- Extremely high strength due to radial compression on the hermetically sealed glass
- Very high impact strength and thermal shock resistance due to prestressing
- Operates under positive or negative pressure
- Certification on material and pressure rating is available, typical of ASME code requirements

CANTY FUSEVIEW™ VS. OTHERS

- No loss of glass temper over time
- Scratches do not affect safety or life
- Unlike tempered glass, a Fuseview™ will not blow out if the surface is damaged
- No extra gaskets, shims, packing, or retaining rings to worry about



CANTY

JM Canty Inc
JM Canty Intl Ltd

Buffalo, NY USA
Dublin, Ireland

Ph: (716) 625 4227
Ph: + 353 (01) 882 9621

Fax: (716) 625 4228
Fax: +353 (01) 882 9622

www.jmcanty.com

Document P/N: TA7653-1 Rev 10

All registered trademarks are the property of their respective owners.

FUSEVIEW™ TRI-CLAMP® SPECIFICATIONS FLUSH MOUNT

SIZE	F	G	H	TEMP RATING
1" / 1.5" / 40mm	.94" [23.9mm]	1.98" [50.3mm]	.68" [17.3mm]	450°F [232°C]
2" / 50mm	1.18" [30mm]	2.52" [64mm]	.68" [17.3mm]	450°F [232°C]
2.5"	1.50" [38.1mm]	3.05" [77.5mm]	.68" [17.3mm]	450°F [232°C]
3" / 65mm	2.00" [50.8mm]	3.58" [90.9mm]	.68" [17.3mm]	450°F [232°C]
3.5" / 80mm	2.50" [63.5mm]	4.17" [106mm]	.68" [17.3mm]	450°F [232°C]
4" / 100mm	3.00" [76.2mm]	4.69" [119.1mm]	.68" [17.3mm]	450°F [232°C]
6"	4.00" [101.6mm]	6.57" [166.9mm]	.68" [17.3mm]	450°F [232°C]
8"	5.70" [144.8mm]	8.57" [217.7mm]	.68" [17.3mm]	450°F [232°C]

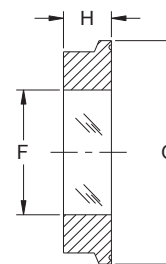
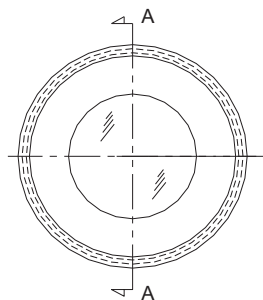

SECTION A-A

FULL VIEW STANDARD MOUNT (FM Approved)

SIZE	A	B	C	D	GLASS THICKNESS E	TEMP RATING
1"	1.44" [36.6mm]	2.00" [50.8mm]	.86" [21.8mm]	1.98" [50.3mm]	.75" [19mm]	450°F [232°C]
1.5"	1.44" [36.6mm]	3.00" [76.2mm]	1.36" [34.5mm]	1.98" [50.3mm]	.75" [19mm]	450°F [232°C]
2"	1.44" [36.6mm]	3.63" [92.2mm]	1.86" [47.2mm]	2.52" [64mm]	.75" [19mm]	450°F [232°C]
2.5"	1.44" [36.6mm]	4.50" [114.3mm]	2.37" [60.2mm]	3.05" [77.5mm]	.75" [19mm]	450°F [232°C]
3"	1.44" [36.6mm]	5.00" [127mm]	2.87" [72.9mm]	3.58" [90.9mm]	.75" [19mm]	450°F [232°C]
4"	1.44" [36.6mm]	6.00" [152.4mm]	3.81" [96.8mm]	4.69" [119.1mm]	.75" [19mm]	450°F [232°C]
6"	1.44" [36.6mm]	8.00" [203.2mm]	5.70" [144.8mm]	6.57" [166.9mm]	.75" [19mm]	450°F [232°C]

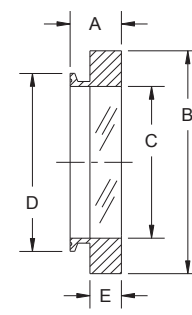
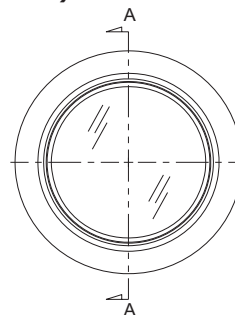

SECTION A-A

Ordering Information

HOW TO ORDER: Select the appropriate options and build a part number as shown:

EXAMPLE:

S A 1 0A0

MODEL:

4 = Fuseview™ Tri-Clamp®

A = Flex Mount Tri With Tapped Holes and Brackets

B = Flex Mount Tri With Tapped Holes

SIZE:

FLUSH:

8 = 1" / 1.5" Flush / 40mm

9 = 2" Flush / 50mm

A = 2.5" Flush

B = 3" Flush / 65mm

F = 3.5" / 80mm

C = 4" Flush / 100mm

D = 6" Flush

E = 8" Flush

FULL VIEW:

1 = 1" Full view

2 = 1.5" Full view

3 = 2" Full view

4 = 2.5" Full view

5 = 3" Full view

6 = 4" Full view

7 = 6" Full view

FINISH: (wetted) (non-wetted = 32 µin [.81 µm] Ra)
 0 = 20 µin [.51 µm] Ra (standard)(BPE-SF1)
 C = 15 µin [.38 µm] Ra
 L = 20 µin [.51 µm] Ra Electropolished (BPE-SF5)
 M = 15 µin [.38 µm] Ra Electropolished (BPE-SF4)

MATERIAL: (wetted)

B = 316L Stainless Steel*

C = Alloy C

D = Hastelloy® C276 or equal

E = Hastelloy® C-22® or equal

* Cauty reserves the right to upgrade to Hastelloy® C-family of alloys or equal at their own cost.

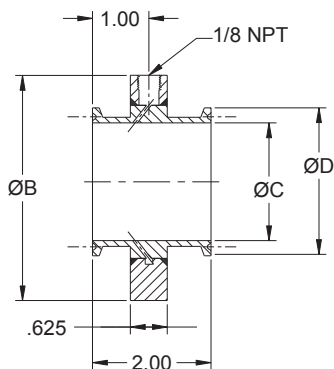
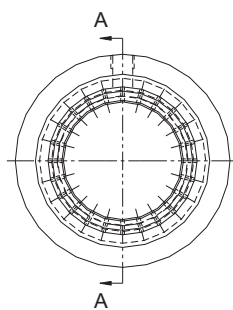

SECTION A-A

Optional Spray Ring

EXAMPLE:

SR6A A

MATERIAL (wetted):

1 = 316L Stainless Steel

4 = Hastelloy® C276 or equal

5 = Hastelloy® C22® or equal

SIZE:

A = 1.5"

B = 2"

C = 3"

D = 4"

E = 6"

All registered trademarks are the property of their respective owners.

CANTY

JM Cauty Inc | Buffalo, NY USA
 JM Cauty Intl Ltd | Dublin, Ireland

Ph: (716) 625 4227
 Ph: + 353 (01) 882 9621

Fax: (716) 625 4228
 Fax: +353 (01) 882 9622

www.jmcauty.com

Document P/N: TA7653-1 Rev 10