

# Oil & Solids in Water & Water & Solids in Oil Analysis

---

Through Dynamic Imaging

## Table of Contents

1. Dynamic Imaging Principle.....	3
2. How it Works.....	3
2.1 Hardware.....	3
2.2 Software Analysis.....	8
2.3 Control Outputs.....	9
3. Sample Field Results.....	10
4. Supporting Documentation List.....	12

## 1. Dynamic Imaging Principle

The fundamental principle of Dynamic Imaging is relatively straightforward. JM Canty's vision based technique works on the basic principle of presenting the fluid (water or oil) between a high intensity light source, and microscopic camera. With the light and camera on opposite sides of the flow stream, images of the fluid and any suspended particulate (oil in water, water in oil, solids, air bubbles) will be captured. These captured images are then sent to the Cantyvision Client Software for analysis, where the suspended particulate is measured under a number of different parameters to provide simultaneous and individual real time size, shape and concentration data for each type of particulate within the fluid flowing in the pipeline.

## 2. How it Works

### 2.1 Hardware

There are 3 critical components to a Dynamic Imaging Based Analyser;

- Microscopic gigabit camera
- High intensity light source
- Flow path between two fused glass windows

The gigabit camera is the simulation of the human eyes in the vision based system. The camera is an IP device with a simple RJ45 connection to allow for easy connection to the analyser network. The camera has the capability to take 30 frames per second, and with the current lens can magnify to a resolution of 0.35 $\mu$ m per pixel, to allow particles as small as 0.7 $\mu$ m to be analysed (maximum magnification dependent on light transmission through fluid, which is usually determined during lab testing phase, and is typically a lesser resolution for water in oil analysis).

The high intensity lighting consists of a quartz halogen light source, focused through the use of a light guide into the area on which the gigabit camera is viewing. Typically it is an 80W light source, originally designed for the illumination of large pressure vessels that is used. All the power of this is focused into the small area which the gigabit camera is monitoring. This is critical in order to catch any moving particulate in freeze frame as it passes the camera in order for the software to be able to analyse it

correctly. In order to guarantee the particulate can be caught in freeze frame, the shutter speed of the camera needs to be increased. As the shutter speed of the camera is increased, there is an increase in light needed which can be achieved through the use of the Canty high intensity light source. Currently the camera can capture particulate moving up to 2.5m per second within a clear fluid (maximum flow speed dependent on light transmission through fluid, which is usually determined during lab testing phase, and is typically a lower speed for water in oil analysis).

Fusion of glass and metal is a unique process whereby a one piece construction component is produced. BoroPlus™ glass in its molten form is poured into the centre of a metallic ring where it flows to the metal wall. At that point due to the chemical make up of BoroPlus™ glass, the glass fuses to the metal. As the unit is then cooled, the metal, having a higher coefficient of expansion than the glass, contracts onto the solidifying glass putting it under uniform radial compression. This fused glass and metal surface can then be finely polished to produce a smooth even surface with no crevices.

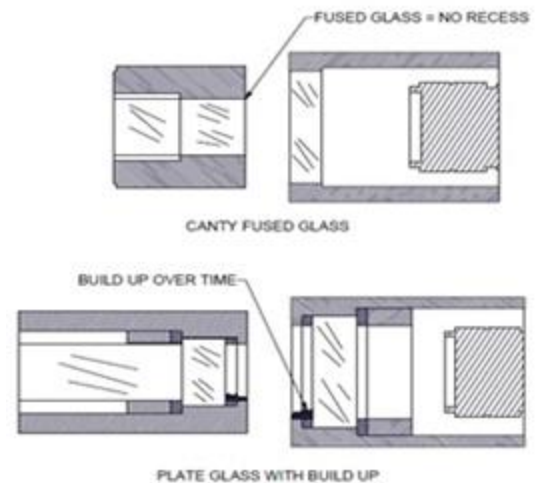

The importance of the fused glass relates to the ability of the unit to stay as clean as possible which is clearly critical for a vision based system. Due to the fact that there are no crevices or spaces between the fused glass and metal, there is nowhere for product to begin to build up. Non-fused glass and metal systems would not have a smooth transition from glass to metal, and it is in this step area that product (oil / solids) would inevitably build up. The fused glass also allows higher pressure operation of the systems (up to 600 Bar possible) due to the fact there is no danger of the glass and metal separating into 2 separate components. A jet spray ring is also included as standard in the system as a means of flushing the glass clean in the event that particulate does become lodged on the glass due to breaks in the flow etc.



Depending on where the measurement is to be taken there are a number of different systems which each combined the 3 key features of camera, fused glass flow path, and high intensity light source;

1. Portable Tru-Flow System (Lab / Portable Unit)

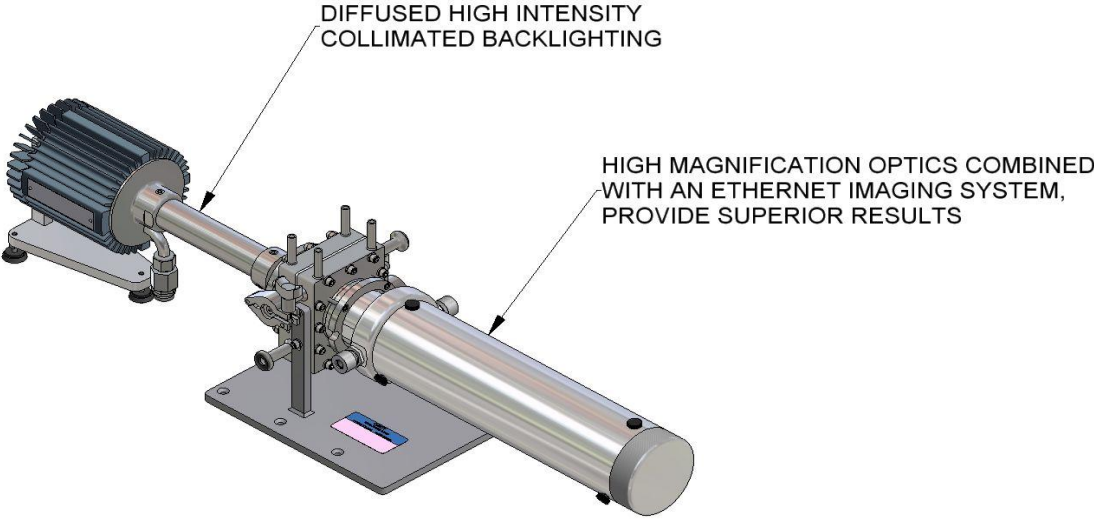
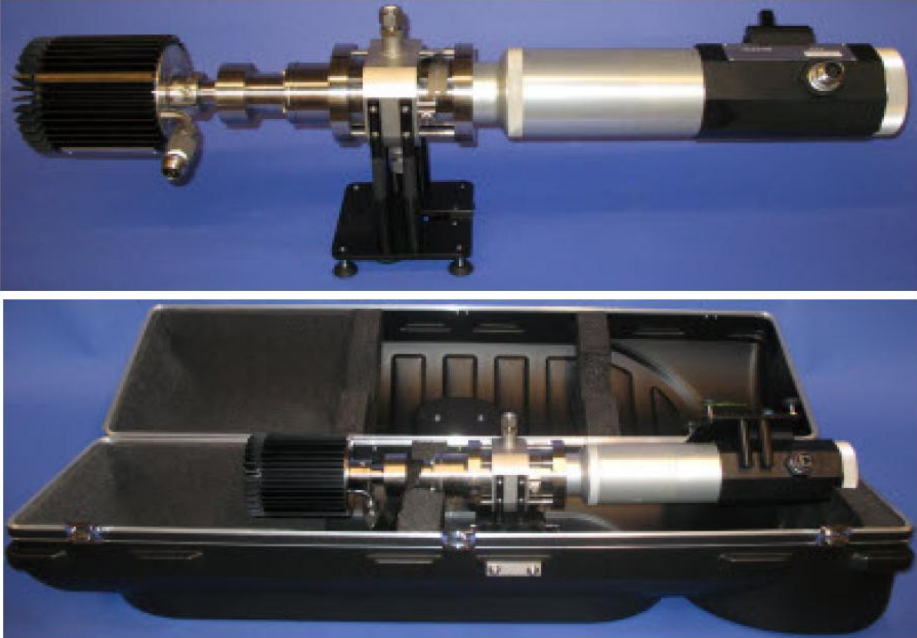

## 2. InFlow Inline System (Up to 22" Pipelines)

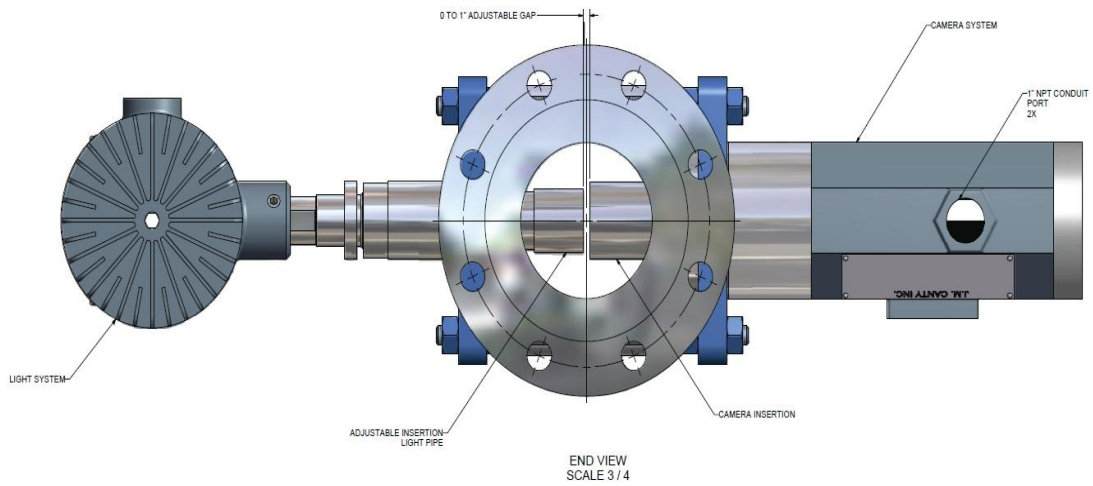

3. Probe Style System (24"+ Pipelines)

HIGH INTENSITY LIGHT SOURCE

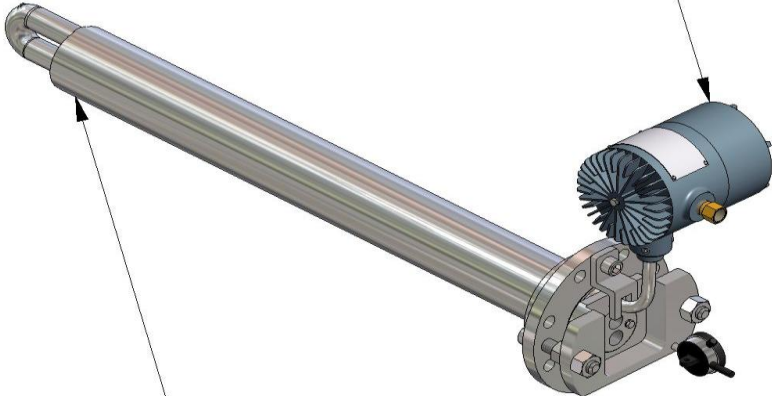

HIGH RESOLUTION IMAGING SYSTEM

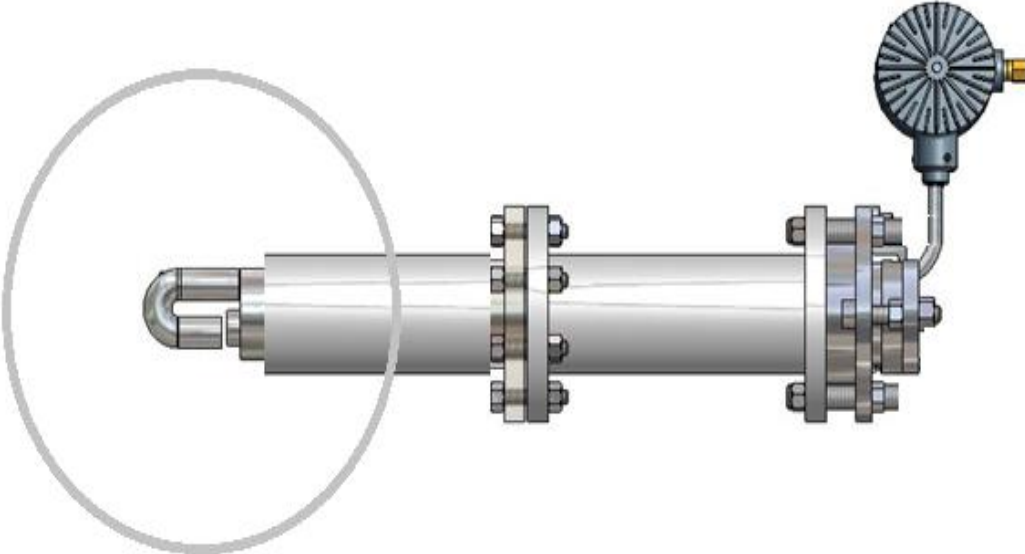

## 2.2 Software

Using Cantyvision software (installed on PC meeting the required particle sizing specifications), the suspended particulate within the retrieved images are analysed under a number of different shape characteristics (major axis, minor axis, area, perimeter, circularity, aspect ratio...). It is because of this that the vision based system is capable of distinguishing between oil droplets (in water), water droplets (in oil) solid particulate and air bubbles within the flow stream.

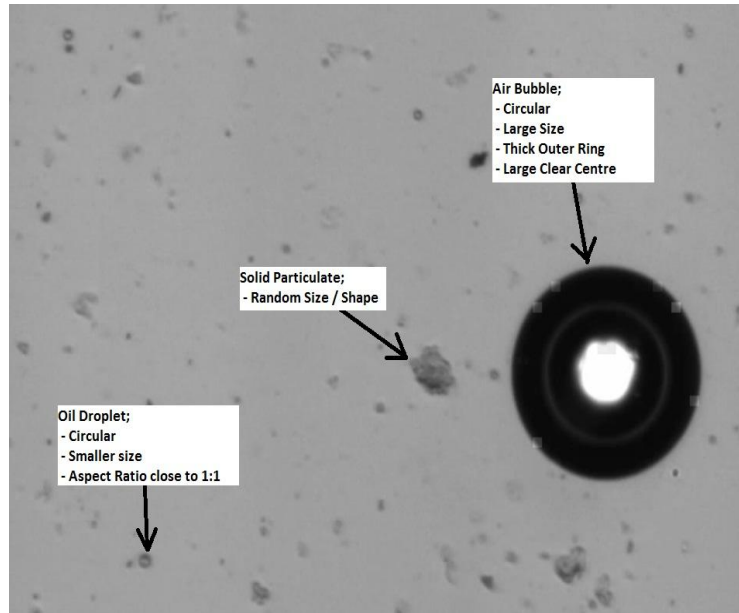

Typically the oil or water droplets will appear circular compared to the solid particulate which will appear randomly shaped. The air bubbles will appear circular but typically will be larger than the water droplets and have a thick black outer ring with a clear centre. These visual differences can be identified by the software through the use of user defined filters to program a particle sizing tool to only count particles that fall within its defined range of measurements. Multiple particle analysis tools can be set up on the one image / streaming view to allow for the individual and simultaneous analysis of oil droplets, water droplets, solid particulate and air bubbles under size and concentration.

The size of any particulate suspended within the flow stream, must be visually calibrated against the area which it takes up on the control PC monitor. This is done by inserting a reticule with a grid of known micron sizes, into the system between the light and camera, to give an image like is shown opposite.

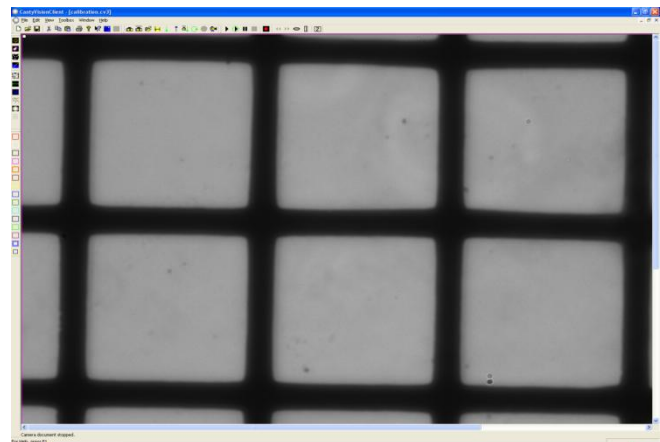

2 points on the grid displayed on the monitor are selected by the operator, and the known value of this distance is inputted to the software which then calculates the pixel scale factor. Therefore, any particle that shows up as 20 pixels wide for example, will be analysed by the software in it's real world micron value.

The concentration calibration is done through the creation of a curve between the total volume of particulate ( $\mu\text{m}^3$ ) over a set number of frames, which is outputted by the software, and the known concentration (parts per million / percent) of created samples which are flowed through the analyser.

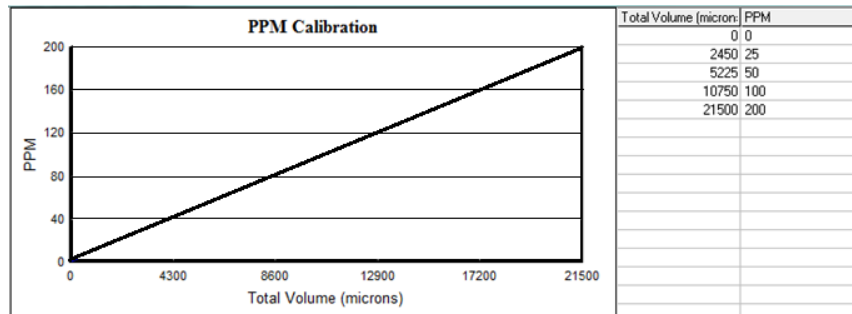

Therefore, when the total volume of particulate over a set number of frames is measured by the software, it can simultaneously output the associated ppm value. This visual calibration can be adjusted to match the operators lab technique if required.

The software operator screen displays real time particle size and concentration (oil & solids done individually and simultaneously) , while also giving the operator a view into the process pipeline.

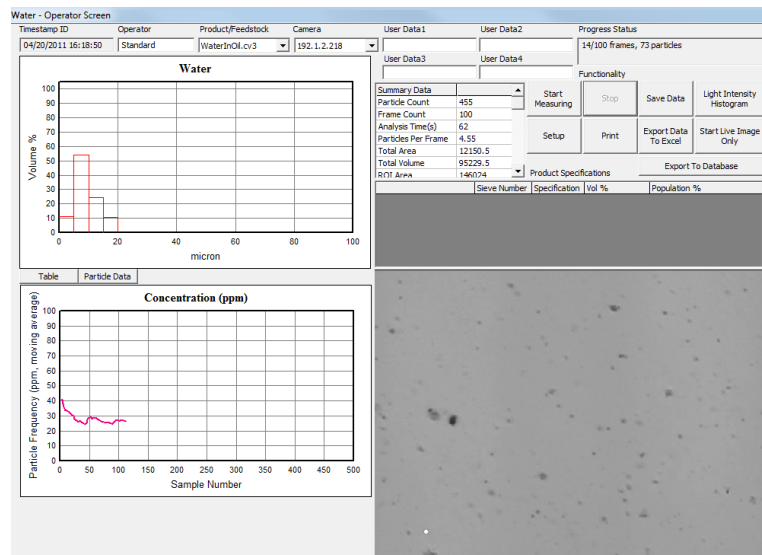

### 2.3 Control Outputs

Outputs from the system are available via OPC or 4-20mA.

### 3. Sample Field Results

#### Case 1:

A Total project took place offshore on the western part of the Dutch continental shelf to compare the Canty system with the OSPAR method.

Current Operator Situation: Samples of water containing light oil condensates are taken every second day from the treating centres, and sent to an external lab for analysis according to the OSPAR method, with results are available within one week.

The JM Canty portable analyser was connected to the discharged water sampling point, downstream of the skimmer tank. In tandem with the vision based analysis, IR measurements were also taken, along with samples sent to the external lab for analysis via the OSPAR GC method

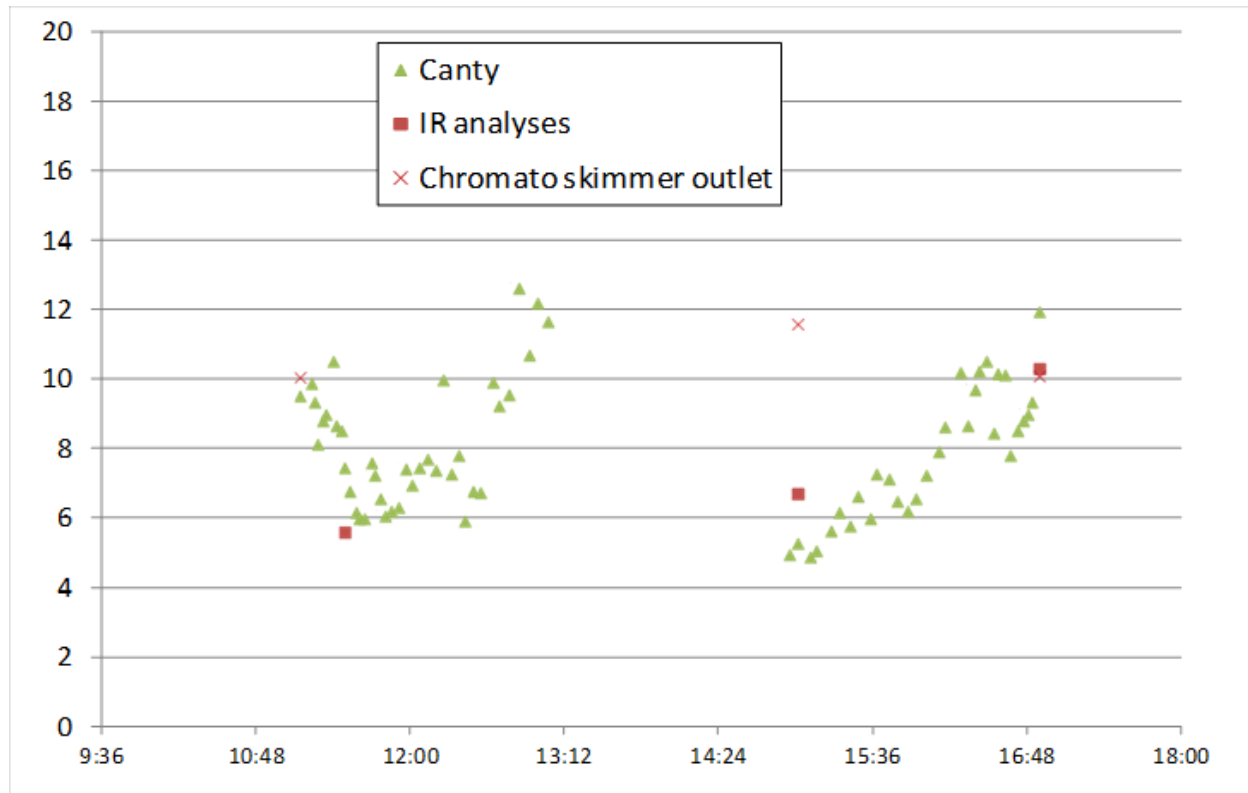

**Case 2:**

A Total project took place at an onshore research facility in France to monitor the performance of the JM Canty analyser versus lab IR analysis over a longer term.

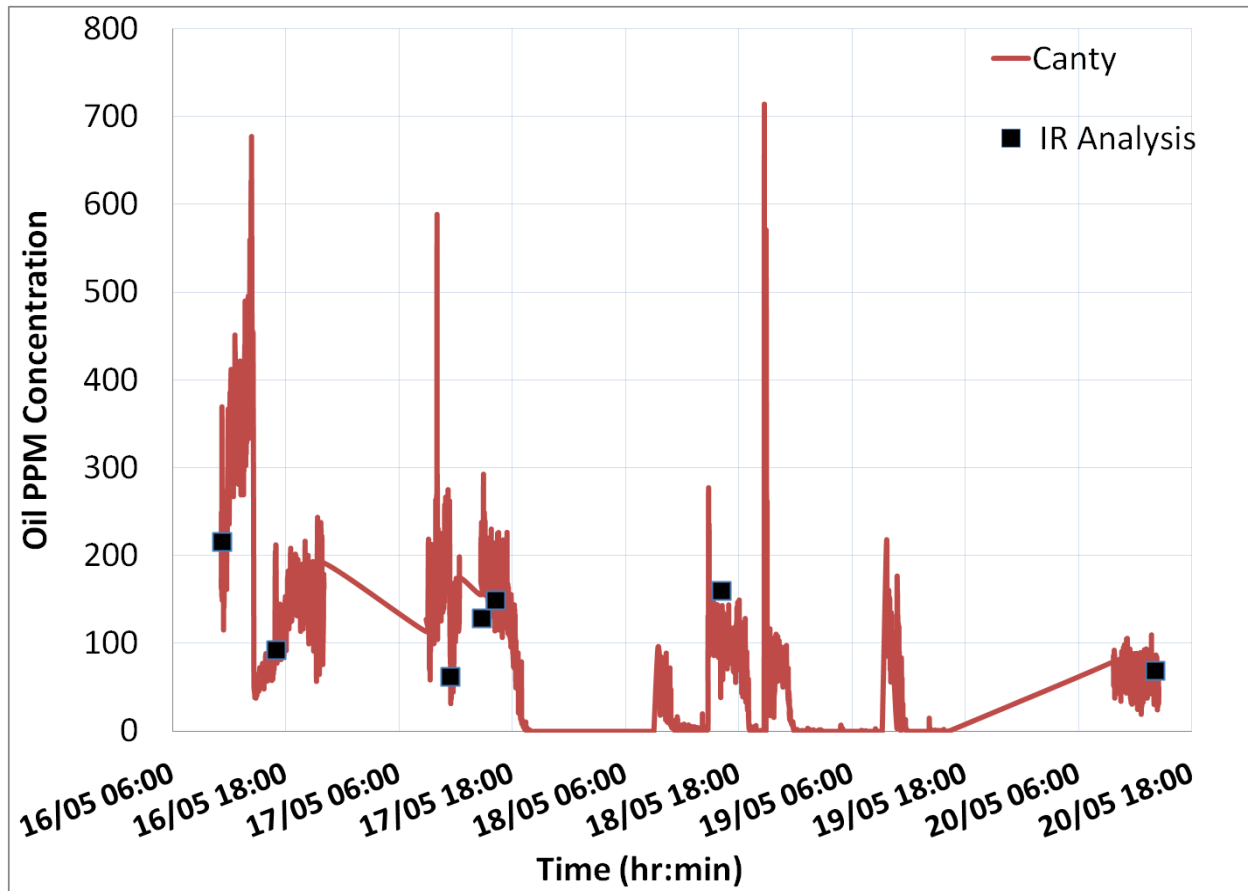

#### 4. Supporting Documentation List

Portable Inflow Datasheet:	TA11317-1
InFlow Inline Datasheet:	TA11014-1
Particle probe Datasheet:	TA8822-1
Cantyvision Client Software:	TA10592-1
OPC Datasheet:	TA10560-1
4-20mA Datasheet:	TA9688-1
Camera ATEX Certificate:	00ATEX1178X
Light ATEX Certificate:	00ATEX1179X