

CANTY

PROCESS TECHNOLOGY

CAMERA SYSTEMS



HOW IT WORKS

J.M. Cauty cameras are patented systems designed to illuminate and view inside a pressure or process vessel through a single connection. There is no need for multiple vessel ports. Cauty supplies an integrally mounted camera and lighting system in a connection as small as a 2" connection. The Ethernet video output can be displayed on a computer in the comforts of a control room, or recorded on any DVR or hard drive. Various software capabilities are available to allow for control and alarm options.

CANTY LIGHTS MAKE IT POSSIBLE

The key to Cauty Camera/Light combination systems is the Cauty light. Cauty uses fiber optic light guides to focus cool, effective light into a process vessel or area. Cool light eliminates product bake-over on the viewing window. Fiber optic light guides have been specifically designed to work in conjunction with cool light to maximize the light transmission into the vessel. The resulting live, remote video image from this illumination is unparalleled!

THE COMPLETE PACKAGE

Cauty can meet all your needs! Included as standard equipment on every camera system are power supplies, a high resolution B & W, color or Ethernet camera, pre-focused lens and WP, IP66, explosion proof or flame proof enclosure. What's more – all wiring and maintenance are external. Recording and control options are available. Cameras can be easily integrated with CautyVision™ software for various process measuring and control functions such as non-contact level control, particle sizing, etc. Please consult the factory for details.

APPLICATIONS

- Polymers – Verify empty, monitor level
- Crystallizers – Liquid and foam level
- Fermentors – Liquid and foam level
- High purity pharmaceutical applications
- Toxic Material – Remote viewing
- Foam and Fluid Level monitoring in:
 - Shredders
 - Nutsche Filters
 - Strippers
 - Hoppers
 - Latex Applications
 - Pressure Vessels

FEATURES

- FM, CSA and ATEX approvals on various models. World wide approvals!
- 10,000 PSI ratings are available
- Up to 2000° F capabilities
- 2" NPT, 2" flange and larger, 3" Tri-Clamp® and larger connections are available.
- High resolution CCD cameras – available in B&W and color, NTSC, PAL and Ethernet output.
- Remotely view your process from the comforts of a control room
- Single nozzle viewing/illuminating (with light)
- Remote light dimming options
- Spray rings are available to keep your window clean

SPECIFICATIONS

CCD Sensor:	½" format. 811(H) x 508(V) typ.
Sensitivity:	Available from .0001 lux usable picture (low light B&W). 0.1 lux is typical (color). Varies with model.
Video Output:	1.0 V p-p, 75Ω typ.(analog) or Ethernet options.
Ambient Temp:	-30°C to 50°C (Consult factory additional temperature needs)
Current Req.:	500 mA typical
Cable:	Cat6 Ethernet (Ethernet Models), RG 59/U 75Ω coaxial cable Suitable CCTV applications analog)
Environmental ratings:	NEMA 4, IP66, Explosion proof (Class 1, Div. 1, Groups B, C & D, Class II, Div. 1, Groups E, F & G) or Flameproof EEx d IIC T6

OPTIONS

- Level/foam control, volume control, in-line particle sizing, color analysis
- Time/date generators – overlay time and date stamp onto video picture
- Data overlay – overlay pH, temp, pressure, etc. on-to video picture
- Various output options - 4-20mA output module available, output via OPC.

CANTY

JM Cauty Inc | Buffalo, NY USA |
JM Cauty Ltd | Dublin, Ireland |

Ph: (716) 625 4227 | Fax: (716) 625 4228
Ph: + 353 (01) 882 9621 | Fax: +353 (01) 882 9622

www.jmcanty.com

Document P/N: TA7259-1 Rev. 14

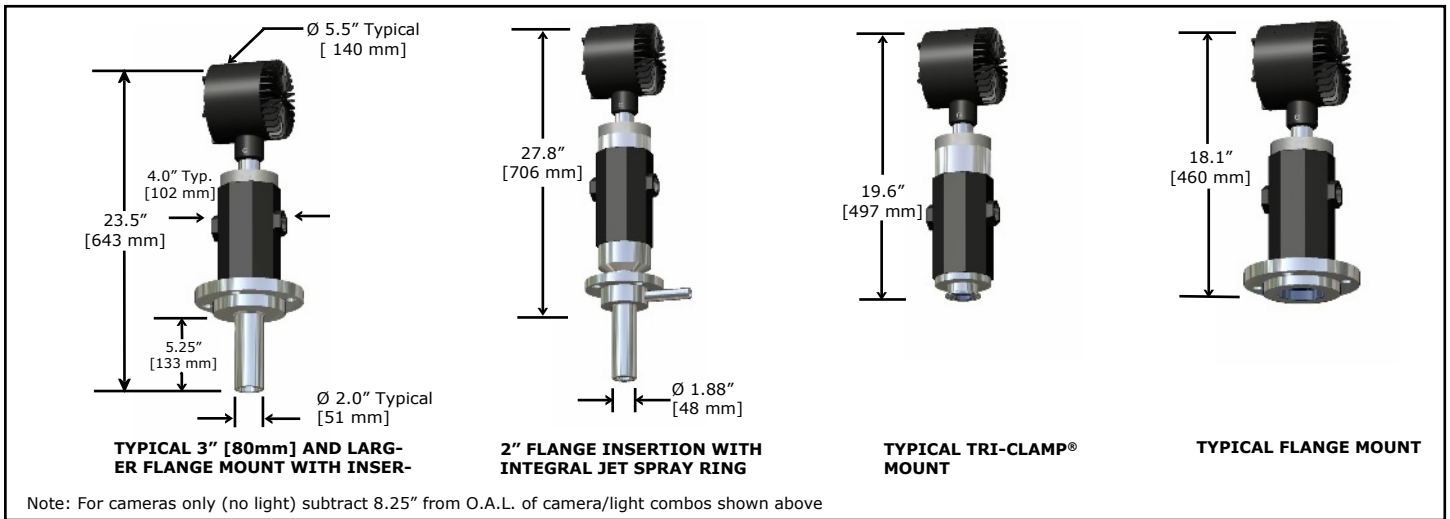

Ordering Information

HOW TO ORDER: Select the appropriate symbols and build a part number as shown:

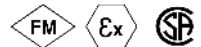

EXAMPLE:

V 6 E 2 1 B D 1 J

VISION SYSTEM

- V - North American standard
- VE - European standard

ENVIRONMENTAL RATINGS

- 6 - NEMA 4 weather proof, IP66
- 7 - Explosion proof (US) or Flame proof (Europe)

CAMERA OPTIONS

- E - Ethernet Video color camera
(Note: Please contact CANTY for analog video options)

LENS OPTIONS

- (Note: Some lenses are not available with certain mounting connections. Consult your binder for details)
- 2 - 56° (H) x 43° (V) x 69° (D)
 - 3 - 69° (H) x 53° (V) x 80° (D)
 - 6 - 41° (H) x 31° (V) x 50° (D)

CAMERA POWER SUPPLY OPTIONS

- 1 - User supplies 120 V AC. Power supply in a non WP or EXP enclosure. User provides enclosure and switch as needed.
- 2 - No power supply required.
- 5 - User supplies 120 V AC. Power supply in a WP enclosure.
- 6 - User supplies 240 V AC. Power supply in an IP/WP enclosure.
- 7 - User supplies 120 V AC. Power supply in an EXP enclosure. PSU enclosure is rated Class I, Div 1, Groups C & D.
- 8 - User supplies 240 V AC. Power supply in non WP or FP enclosure. User provides enclosure and switch as needed.

WETTED MATERIAL OPTION

- B - 316 L Stainless Steel*
- D - Hastelloy® C-276 or equal
- E - Hastelloy® C-22® or equal
- F - Glass (BoroPlus™)**

*Canty reserves the right to upgrade to Hastelloy® C family of alloys or equal at their own cost
 ** Not available with all models

LIGHT OPTIONS

- G - HYL 80 1SRDO (240 V)
- J - HYL 80 1SRDO (120 V)
- N - Camera only - will not accept an integral light
- 0 - Combo w/o light - will accept an existing light (Note: Without a light source the camera cannot maintain WP or EXP integrity)

NON WETTED MATERIAL

- 0 - No flange required (if selecting a flanged model). Select this option when choosing NPT or Tri-Clamp® models also.
- 1 - 150 # carbon steel ANSI flange
- 2 - 150 # 316L stainless steel ANSI flange
- 3 - 300 # carbon steel ANSI flange
- 4 - 300 # 316L stainless steel ANSI flange
- 6 - 16 Bar carbon steel DIN flange
- 7 - 16 Bar stainless steel DIN flange
- 8 - 10 Bar carbon steel DIN flange
- 9 - 10 Bar stainless steel DIN flange

MOUNTING CONNECTION

- Consult factory for additional sizes and ratings.
- B - 2" NPT, 5.25" insertion
 - C - 3" ANSI flange
 - D - 4" ANSI flange
 - E - 2" ANSI flange
 - F - 3" ANSI flange, 5.25" insertion
 - G - 100 mm DIN flange
 - H - 4" ANSI flange, 5.25" insertion
 - J - 100 mm DIN flange, 5.25" insertion
 - K - 2" ANSI flange, 5.25" insertion
 - M - 3" Tri-Clamp® 5.25" insertion
 - P - 4" Tri-Clamp® 5.25" insertion
 - Q - 80 mm DIN flange
 - S - 80 mm DIN flange, 5.25" insertion
 - T - 2" ANSI flange, 5.25" insertion w/integral spray ring
 - U - 4" Tri-Clamp®
 - 3 - 3" Tri-Clamp®
 - 5 - 6" ANSI flange, 5.25" insertion

CANTY

JM Canty Inc | Buffalo, NY USA
 JM Canty Ltd | Dublin, Ireland

Ph: (716) 625 4227 | Fax: (716) 625 4228
 Ph: + 353 (01) 882 9621 | Fax: +353 (01) 882 9622

www.jmcanty.com

All registered trademarks are the property of their respective owners.