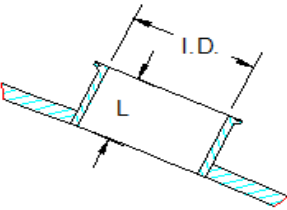
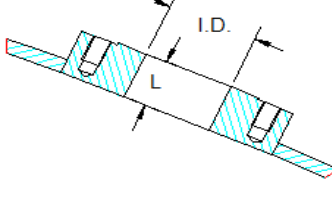
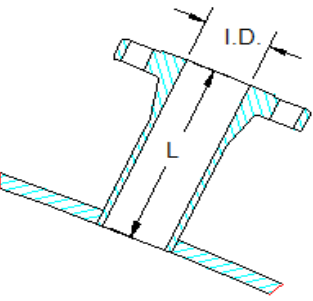

PROCESS CAMERA APPLICATION QUESTIONNAIRE

Date:		Customer:		Representative:	
Sketches / Drawing included:			<input type="checkbox"/> Yes <input type="checkbox"/> No	(If customer can provide a drawing please provide electronically whenever possible)	

ENGINEERING DATA

Design Temp:		Ambient Temp:		Normal Operating Temp:	
Pressure Rating:		Operating Pressure:			
Environmental Rating: <input type="checkbox"/> Explosion Proof Rated <input type="checkbox"/> Weatherproof Rated <input type="checkbox"/> Flame Proof Rated					
Input Voltage: <input type="checkbox"/> 24V DC <input type="checkbox"/> 120V AC <input type="checkbox"/> 230V AC					

Type of Connection:	<input type="checkbox"/> Tri-Clamp	<input type="checkbox"/> Pad Flange	<input type="checkbox"/> Nozzle Flange
			
	Insertion Length (L):	Insertion Length (L):	Insertion Length (L):
	Inside Diameter (I.D.):	Inside Diameter (I.D.):	Inside Diameter (I.D.):

Wetted Material:	<input type="checkbox"/> 316L Stainless Steel <input type="checkbox"/> Hastelloy C276 <input type="checkbox"/> Hastelloy C22	<input type="checkbox"/> 316L Stainless Steel <input type="checkbox"/> Hastelloy C276 <input type="checkbox"/> Hastelloy C22 <input type="checkbox"/> Glass Wetted	<input type="checkbox"/> 316L Stainless Steel <input type="checkbox"/> Hastelloy C276 <input type="checkbox"/> Hastelloy C22
------------------	--	---	--

Spray Ring:	<input type="checkbox"/> Yes <input type="checkbox"/> No	<input type="checkbox"/> Yes <input type="checkbox"/> No	
Wetted Surface Finish:	<input type="checkbox"/> 20 µin [.51 µm] Ra	Non-wetted Retaining Flange Material:	
	<input type="checkbox"/> 15 µin [.38 µm] Ra	<input type="checkbox"/> Stainless Steel	<input type="checkbox"/> Stainless Steel
	<input type="checkbox"/> 20 µin [.51 µm] Ra EP	<input type="checkbox"/> Carbon Steel	<input type="checkbox"/> Carbon Steel
	<input type="checkbox"/> 15 µin [.38 µm] Ra EP	<input type="checkbox"/> Customer to supply	<input type="checkbox"/> Customer to supply

Application:	<input type="checkbox"/> View Only <input type="checkbox"/> Level Analysis <input type="checkbox"/> Foam Detection	<input type="checkbox"/> Other, please describe:
--------------	--	--

Notes / Sketch Area:	
----------------------	--