

CANTY

PROCESS TECHNOLOGY

3-D ROCKSIZER™ ONLINE SIZING SYSTEM



THE CANTY ADVANTAGE

The control of rock and aggregate size is critical, as crushing mills tend to have a high rate of out of spec production. Sizing the crushed rock and detecting when it is not the optimum size saves a significant amount of time and money by avoiding product return and rework. The JM Canty RockSizer™ allows quick sizing of aggregate to allow for real time adjustments to the process and to keep the output in spec. The RockSizer™ is a vision-based measurement system used with a Canty Vector for aggregate, determining particle size, shape, and distribution thereby eliminating the need for sieve analysis.

The RockSizer™ includes two B&W cameras, dual lighting systems, a hopper and gate system, and a vibratory feeder to present the sample material to the cameras and lights in free fall. The RockSizer™ electronics are packaged in a rugged, weatherproof, skid mounted frame designed to meet the demanding requirements of many industries, including the aggregate industry. The camera video is provided to the Canty Vector System for quick and precise particle size analysis. The vector output matches sieve and screen data directly.

FEATURES

- Outdoor Lab Analyzer, Weatherproof Rated
- Particle Distribution by Major, Minor Diameter, Area, Perimeter Available with the Canty Vector System
- Real-time, On-line Particle Size Analysis
- Dual Backlighting for True Shape Illumination
- Easy, Rapid System Configuration
- Rugged, Skid Mounted Frame
- Large Hopper to feed the product into the RockSizer™
- Gate system allows for precise feed control of the product
- Dual camera systems to allow for twice the feed rate of single camera system

APPLICATIONS

- Aggregate
- Crusher Control
- Iron Ore Pellets
- Milling Controls
- Potato & Agricultural Product
- Screen Break
- Screen Blinding
- Wood chip
- Many More

SPECIFICATIONS

Aggregate:	1/10" – 2" Particle/Object. 500-6000 micron, .75"-9" Models also available. Consult Factory.
Rating:	NEMA 4 Weather proof (EXP Available)
Power:	120V AC, 60Hz, (230V AC, 50Hz available) Single Phase, 900W
Dimensions:	Approx. 6 ft. (L) X 3 ft. (W) X 5 ft. (H)
Weight:	Approx. 1250 lbs

BENEFITS

- Reduces Lab Screening Labor
- Output Matches Sieve / Screen Data - Direct Replacement
- Fast Pay Back

CANTY

Buffalo, NY USA
Ph: (716) 625 4227

Dublin, Ireland
Ph: + 353 (01) 882 9621

Phuket, Thailand
Ph: + 66 (83) 968 9548

www.jmcanty.com

Document P/N: TA9308-1 Rev. 9

ORDERING INFORMATION

HOW TO ORDER: Select the appropriate symbols and build a part number as shown:

EXAMPLE:

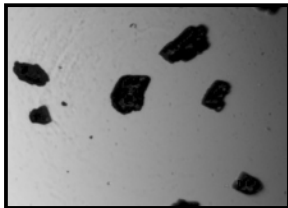
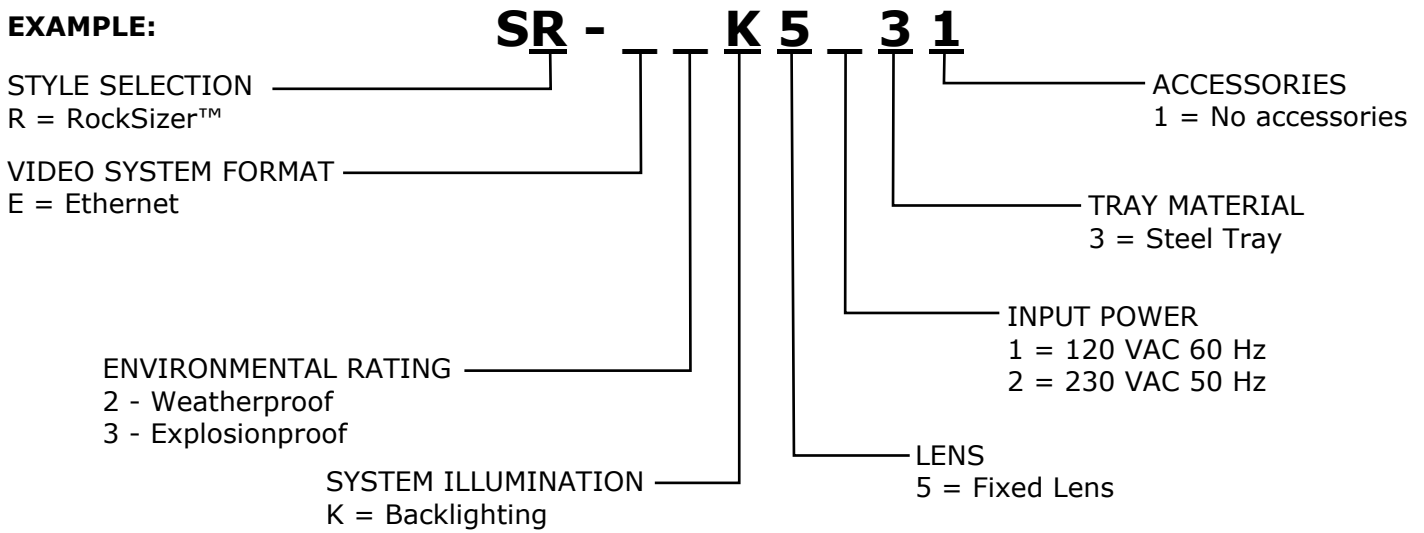

Live Image



Digitizer Image

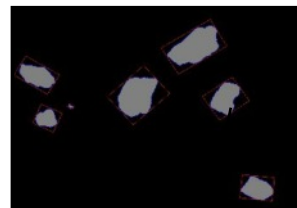

Sizing Image

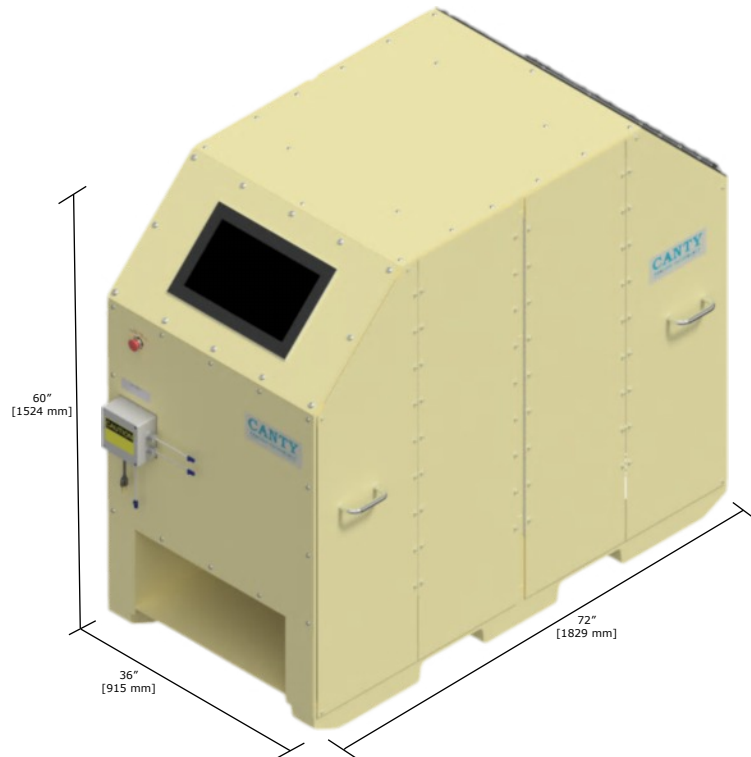
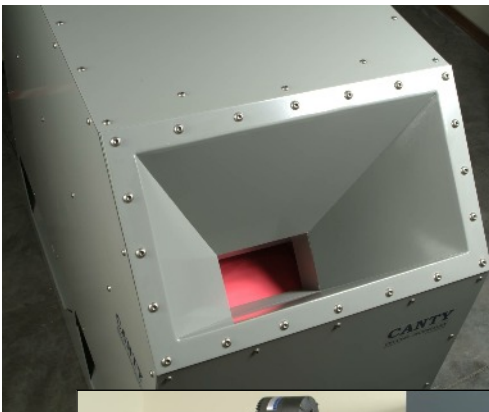

CANTY

Buffalo, NY USA
Ph: (716) 625 4227

Dublin, Ireland
Ph: + 353 (01) 882 9621

Phuket, Thailand
Ph: + 66 (83) 968 9548