

# SHEET 1 OF 2

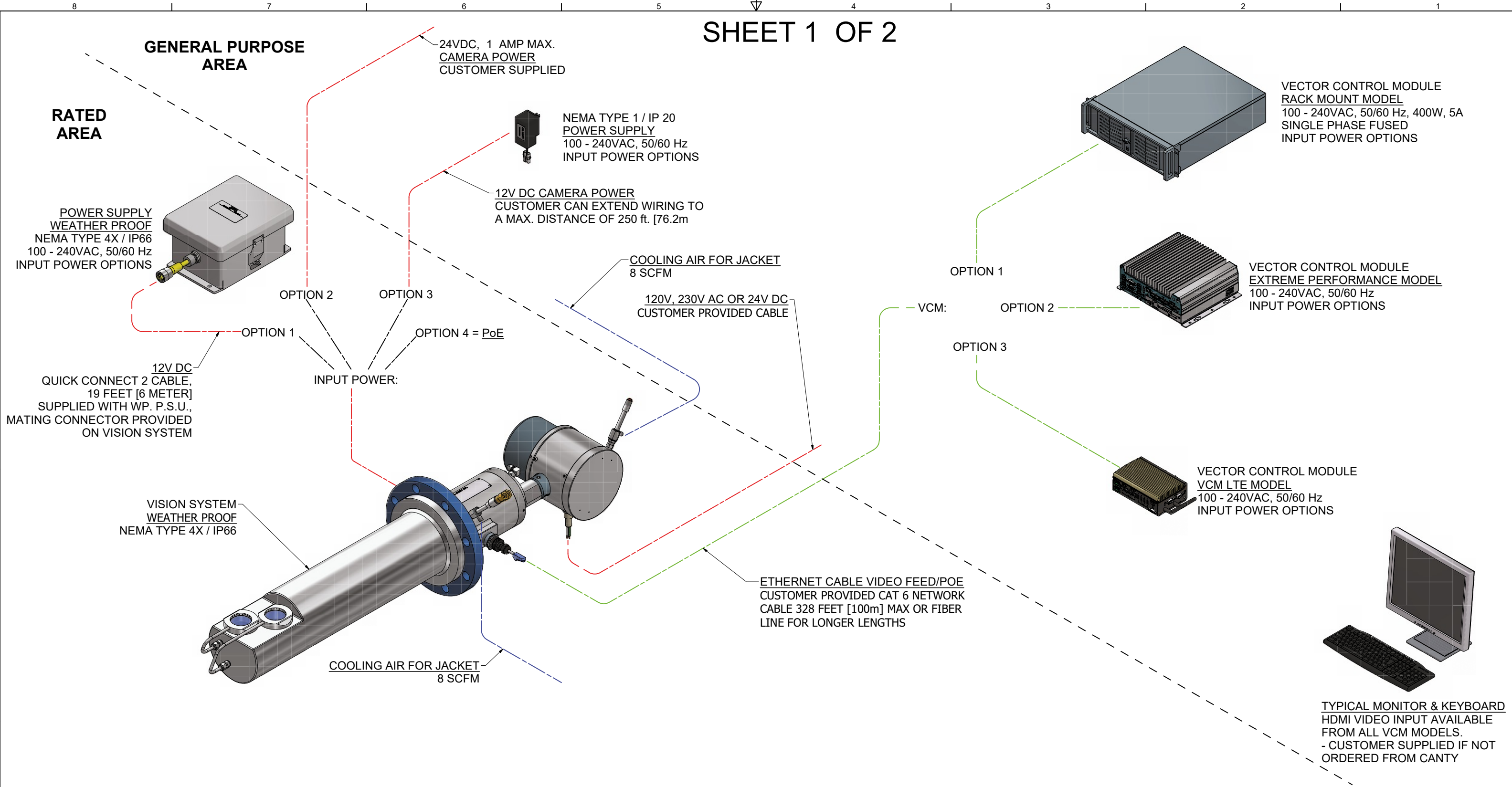

- NOTES:**
- CAMERA IS RATED FOR 150 PSI [10.3 bar] @ 400°F [204°C] MAX.
  - WETTED MATERIALS: ALLOY C276, 316L, BORO PLUS GLASS, & VITON O-RINGS.
  - NON-WETTED MATERIALS: S.S., A105 C.C., & ANODIZED ALUMINUM.
  - ANY WIRING AND CONNECTORS ARE SUPPLIED BY CUSTOMER AND MUST BE COMPLETED IN ACCORDANCE WITH APPLICABLE REGULATIONS.
  - ETHERNET CAMERA IS CONNECTED TO CUSTOMER'S DEDICATED ETHERNET NETWORK VIA CAT6 ETHERNET CABLE.
  - EACH ETHERNET VISION SYSTEM IS PROVIDED WITH A LICENSE OF CANTYVISION SOFTWARE INSTALLED ON A CANTY VECTOR CONTROL MODULE (VCM).
  - IF SWITCHES ARE REQUIRED PLEASE SEE MEDIA CONVERTER DATASHEET P/N TA11950-1024.
  - ALL INFORMATION SUBJECT TO CHANGE WITHOUT NOTICE.

<b>NOTICE</b> THIS DRAWING IS THE PROPERTY OF J.M. CANTY AND MUST BE RETURNED WITHOUT REPRODUCTION OR DUPLICATION, AT ANY TIME UPON REQUEST, BUT IN ANY EVENT AS SOON AS IT HAS SERVED THE PURPOSE FOR WHICH IT WAS FURNISHED. WHILE IN THE POSSESSION OF THE RECIPIENT, IT MUST BE PROPERLY SAFEGUARDED AGAINST DISCLOSURE TO ANYONE EXCEPT THOSE EMPLOYEES WHO REQUIRE IT FOR WORK OR JOB. THE RECIPIENT MUST KEEP CONFIDENTIAL AND REQUIRE HIS (HER) EMPLOYEES TO KEEP CONFIDENTIAL THE INFORMATION CONTAINED HERE ON.		<b>IMPORTANT</b> UNLESS NOTED THE PRIMARY DIMENSIONS ARE IN INCHES AND THE SECONDARY UNITS ARE IN MILLIMETERS.		DRAWN BY RFM	DATE 15-Jul-22	J.M. CANTY INC. 6100 DONNER RD. BUFFALO, N.Y. 14094 U.S.A.	<b>CANTY</b> WWW.JMCANTY.COM	J.M. CANTY INTL. LTD. BALLYCOOLIN BUS. PK. BLANCHARDSTOWN DUBLIN 15, IRELAND
APPROVAL RFM	DATE 15-Jul-22	ENGINEERING ANALYSIS CURRENT	DATE					
MFG. APPROVAL PENDING	DATE	QUALITY CONTROL VJS	DATE	TITLE RIGHT ANGLE SPRAY DRYER CAMERA TYPICAL INSTALLATION DETAIL		REVISION 0	FILE NAME TA11950-1090	SCALE AS NOTED
						SIZE D	SHEET 1 OF 2	

# SHEET 2 OF 2

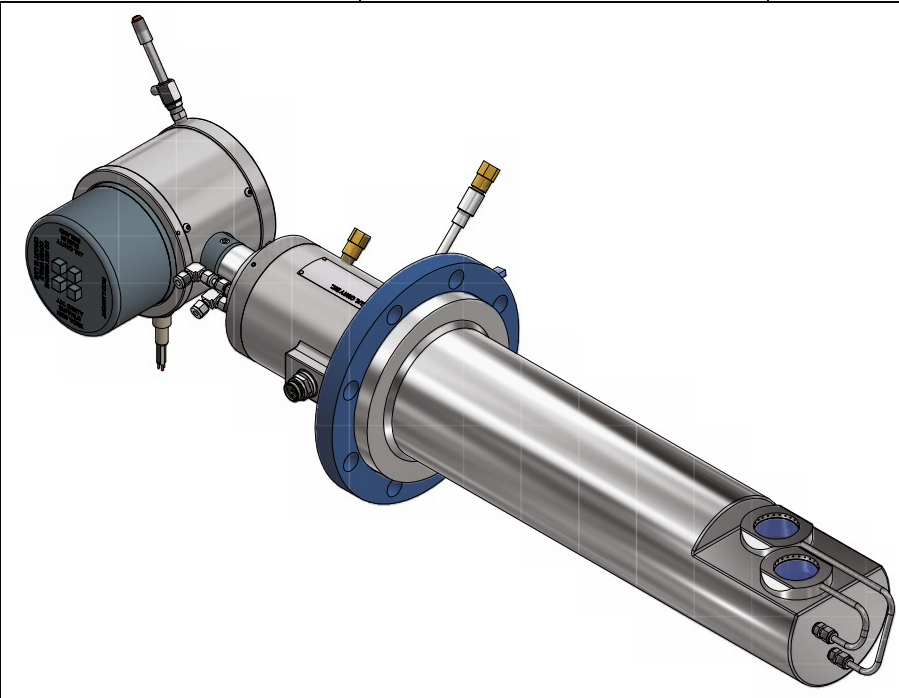

ISOMETRIC VIEW  
SCALE 1 / 4

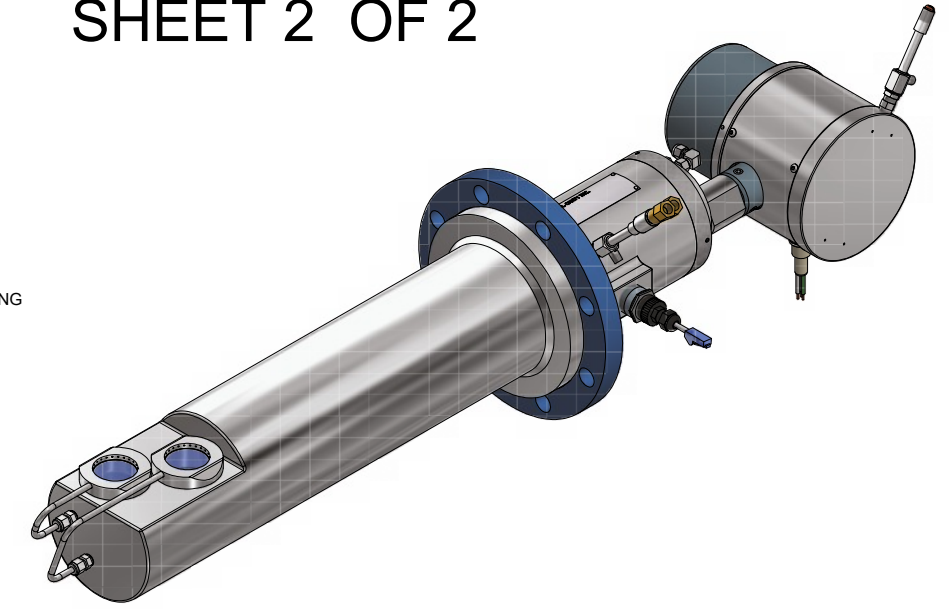
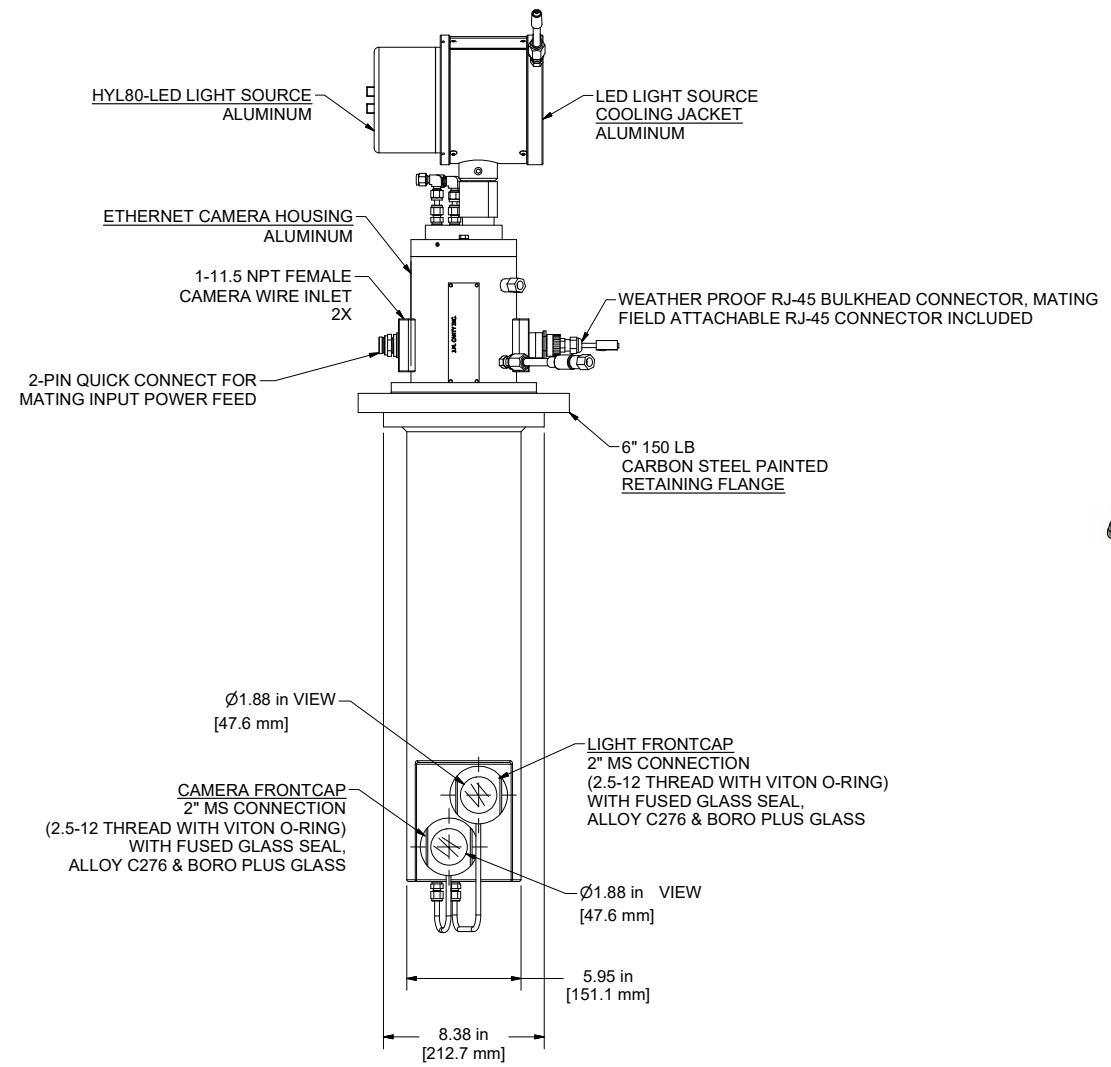

ISOMETRIC VIEW  
SCALE 1 / 4

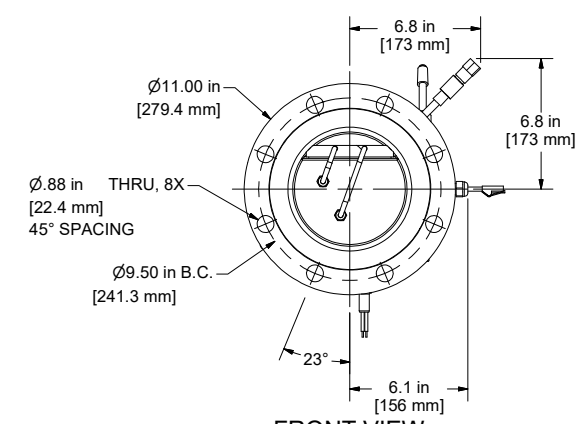
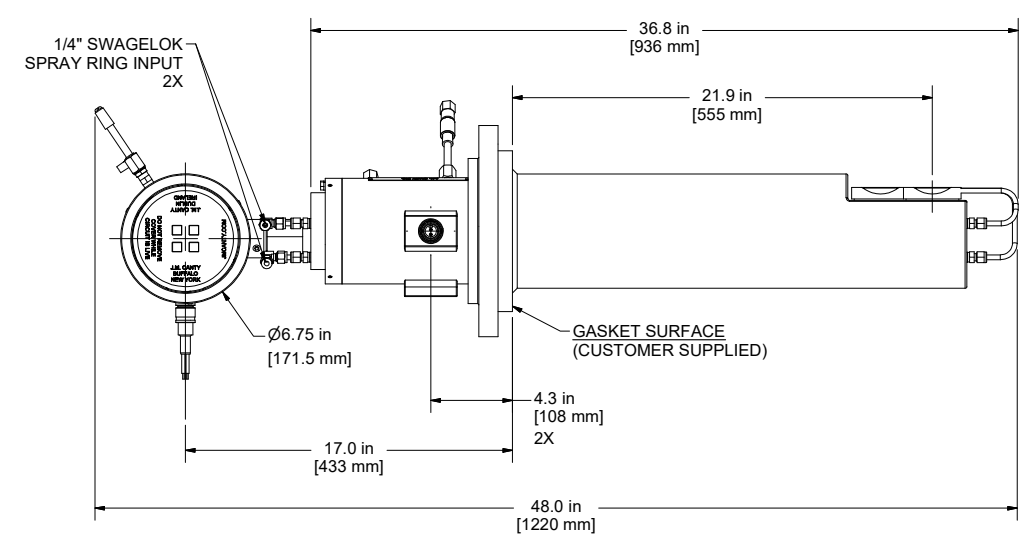

FRONT VIEW  
SCALE .20 : 1

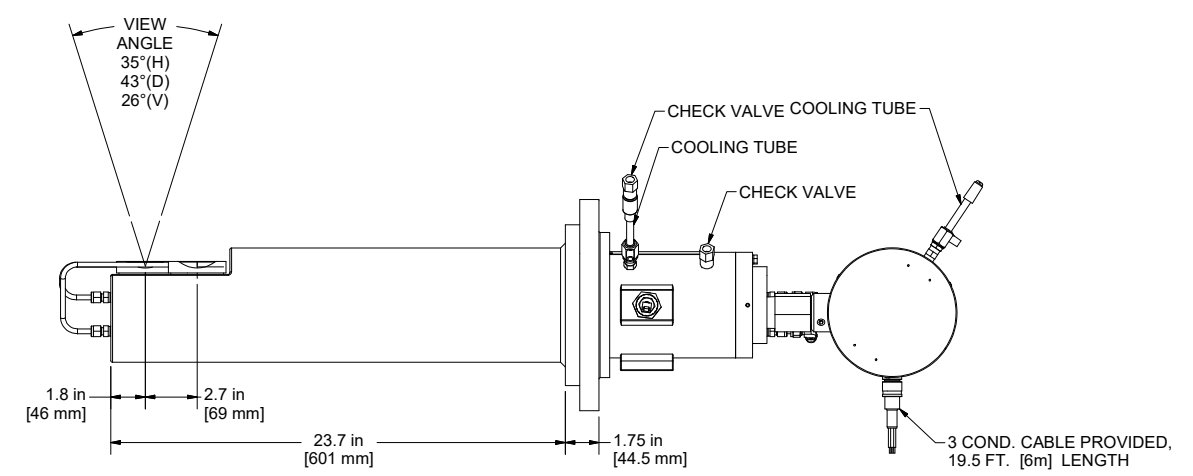

- NOTES:**
- CAMERA IS RATED FOR 150 PSI [10.3 bar] @ 400°F [204°C] MAX.
  - WETTED MATERIALS: ALLOY C276, 316L, BORO PLUS GLASS, & VITON O-RINGS.
  - NON-WETTED MATERIALS: S.S., ANODIZED ALUMINUM.
  - ESTIMATED WEIGHT: 98 LBS [44 Kg].
  - ALL DIMENSIONS LISTED ARE APPROXIMATE AND MAY VARY SLIGHTLY DUE TO MANUFACTURING TOLERANCES AND ASSEMBLY.

<b>NOTICE</b> THIS DRAWING IS THE PROPERTY OF J.M. CANTY AND MUST BE RETURNED WITHOUT REPRODUCTION OR DUPLICATION, AT ANY TIME UPON REQUEST, BUT IN ANY EVENT AS SOON AS IT HAS SERVED THE PURPOSE FOR WHICH IT WAS FURNISHED. WHILE IN THE POSSESSION OF THE RECIPIENT, IT MUST BE PROPERLY SAFEGUARDED AGAINST DISCLOSURE TO ANYONE EXCEPT THOSE EMPLOYEES WHO REQUIRE IT FOR WORK OR JOB. THE RECIPIENT MUST KEEP CONFIDENTIAL AND REQUIRE HIS (HER) EMPLOYEES TO KEEP CONFIDENTIAL THE INFORMATION CONTAINED HERE ON.		<b>IMPORTANT FOR THE REQUIRED MANUFACTURING SPECIFICATIONS SEE DOCUMENT #A4955</b>		DRAWN BY RFM APPROVAL RFM ENGINEERING ANALYSIS CURRENT MFG. APPROVAL PENDING QUALITY CONTROL VJS	DATE 15-Jul-22 DATE 15-Jul-22 DATE DATE DATE	J.M. CANTY INC. 6100 DONNER RD. BUFFALO, N.Y. 14094 U.S.A. <b>CANTY</b> WWW.JMCANTY.COM	J.M. CANTY INTL. LTD. BALLYCOOLIN BUS. PK. BLANCHARDSTOWN DUBLIN 15, IRELAND
				TITLE <b>RIGHT ANGLE SPRAY DRYER CAMERA TYPICAL INSTALLATION DETAIL</b>			
REVISION 0		FILE NAME TA11950-1090		SCALE AS NOTED		SIZE D	SHEET 2 OF 2