

# Particles in Cooling Water

Particle Detection in Cooling Water for Data Centers



## The Application of Dynamic Imaging to Detect Particles in Cooling Water Systems

Heer Mehta

J.M. Canty

In data center cooling systems, maintaining water quality is critical for reliable thermal performance and long-term infrastructure protection. Particulate matter in cooling water can compromise system efficiency and integrity, making accurate measurement and quantification essential for assessing cleanliness and stability as advanced liquid cooling architectures are adopted.

Continuous particle monitoring provides real-time insight into particle size and concentration, enabling informed decisions on filtration, maintenance, and operational control. This paper examines the application of the CANTY InFlow™ analyzer, a dynamic imaging technology that detects solids, droplets, gas bubbles, and other foreign materials directly within cooling water flow.

**CANTY**  
Driven by Vision

## Contents

Overview of Cooling Water for Data Centers	3
Current Water Testing Techniques	4
Current Water Testing Techniques Cont'd	5
How Dynamic Imaging Works	6
InFlow™ Hardware	7
InFlow™ Hardware Cont'd & Configurations	8
Connectivity	9
Data Outputs For Particles in Water Cooling Systems	10
Conclusions	11
References	12

## Introduction

Dynamic imaging involves flowing cooling water through an inline analyzer that captures microscopic images of the fluid and analyzes those images to detect the presence of particles. These particles may include droplets, gas bubbles, or solid materials. Because the acquired images are two-dimensional and these materials exhibit distinct physical appearances, dynamic imaging analyzers are capable of simultaneously detecting, sizing, and measuring the concentration of each material independently.

When the CANTY Inflow™ analyzer is installed inline within a data center cooling loop, the analyzer is capable of detecting solid particles at the micron scale and above. When detected, the analyzer outputs signals corresponding to particle size, count, concentration, providing continuous visibility into cooling water quality without interrupting system operation.

These outputs allow the cooling system to respond more quickly than conventional monitoring methods, such as conductivity sensors, fluorescent tracing chemicals, or pH sensors. By monitoring particles in real time as they pass through an inline analyzer, operators can accurately assess cooling water quality without taking separate samples. Since particle concentration in well-maintained cooling loops are usually low, relying on manual sampling can lead to uncertain results, and small sample volumes increase the chance of contamination from handling or containers. Real-time particle data can help determine when a line requires filtration maintenance, flushing, or cleaning, ensuring consistent system performance. Measurements from an inline dynamic imaging analyzer are therefore critical for optimizing cooling water quality, protecting hardware, and maintaining thermal efficiency.

## Overview of Cooling Water in Data Centers

Cooling water is an important part of data center operations, the equipment generates significant heat that must be efficiently removed. Poor water quality can reduce heat transfer efficiency, allowing equipment to overheat, which can lead to hardware damage, or system shutdowns. Particles in the water can cause scaling, corrosion, or clogging in pipes, further reducing cooling performance and increasing the risk of downtime. To prevent these issues, cooling water is typically managed through filtration, chemical treatment to monitor pH, and recirculation, with continuous monitoring to ensure that particle levels remain within safe operating limits.

Maintaining high-quality cooling water is essential for stable and efficient data center operation. Properly treated water enhances heat transfer performance, allowing cooling systems to operate within design specifications while minimizing energy demand. Good water quality also reduces corrosion, fouling, and particulate deposition on heat exchangers, pumps, and piping, extending equipment lifespan and reducing maintenance requirements. Consistent control of water quality parameters supports reliable system performance, lowers the risk of unplanned downtime, and helps maintain overall cooling system efficiency as thermal loads increase.

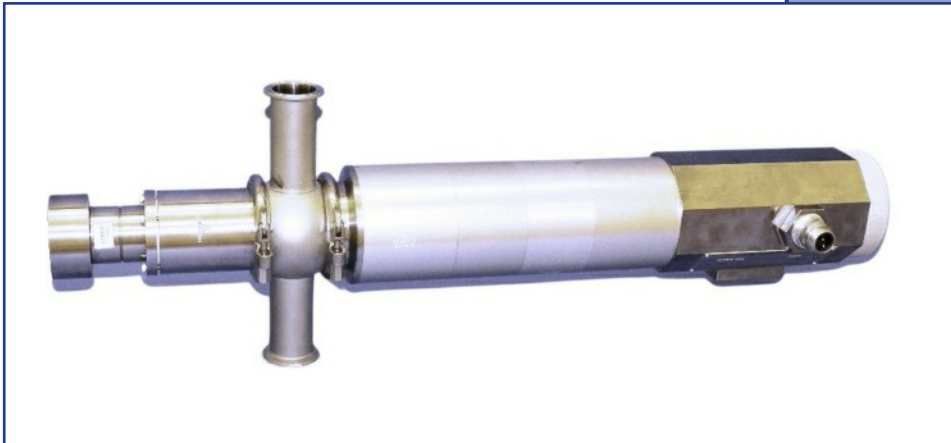

As data centers continue to increase in size and power density, maintaining consistent cooling water quality becomes more challenging and more critical. Higher thermal loads place greater demands on cooling infrastructure, making systems more sensitive to even small changes in water quality. Fluctuations in particle concentration or chemical balance can quickly impact heat exchanger performance and system stability. As a result, reliable and continuous monitoring of cooling water is necessary to detect early signs of contamination, assess treatment effectiveness, and ensure long-term operational reliability.

## Current Water Testing Techniques

Some common methods for detecting and measuring particles in cooling water are (1) Conductivity and pH sensors, (2) Blowdown reuse analysis, and (3) Manual analysis. Conductivity sensors are used to identify leaks by measuring the water's electrical current in  $\mu\text{S}/\text{cm}$ . This is dependent on the concentration of ions in the solution. To determine if there is a leak, the sensors are placed in between the possible source to locate a difference in conductivity. The pH sensors are used to identify contaminant levels, which depending on the coolant's pH (on average 7.5-9), it is likely the process is contaminated with dissolved solids when fluctuated. Although they provide useful information about overall water chemistry, they do not directly detect or measure particulate matter.

During blowdown reuse, the concentrated water is periodically removed to control the buildup of contaminants and total dissolved solids (TDS) to protect the system health. This needs to be properly calibrated otherwise problems may arise. Excessive blowdown wastes large volumes of water and energy and insufficient blowdown can lead to scale buildup and chemical instability. Since blowdown only represents a small portion of the system, it may not reflect particle activity occurring in other areas of the cooling loop.

Manual inspection involves collecting water samples and examining them for visible particles and discoloration, this can also be taken for sampling to provide detailed particle size and concentration. This method is time-consuming and limited to what can be seen with visual inspection or basic magnification. This may not represent the particles within the cooling system. With low particle concentrations, individual samples may not reflect intermittent particle activity, and small samples are more likely to be contaminated during collection.



The CANTY InFlow™ eliminates many limitations associated with sampling-based monitoring, including inconsistent results, reduced fluid clarity, increased viscosity, and interference from gas bubbles. The analyzer can be installed directly inline within a cooling loop or used in a laboratory configuration and operates fully automatically, providing continuous data without operator intervention. It captures images in real time and measures particle size, two-dimensional shape, and concentration as particles pass through.

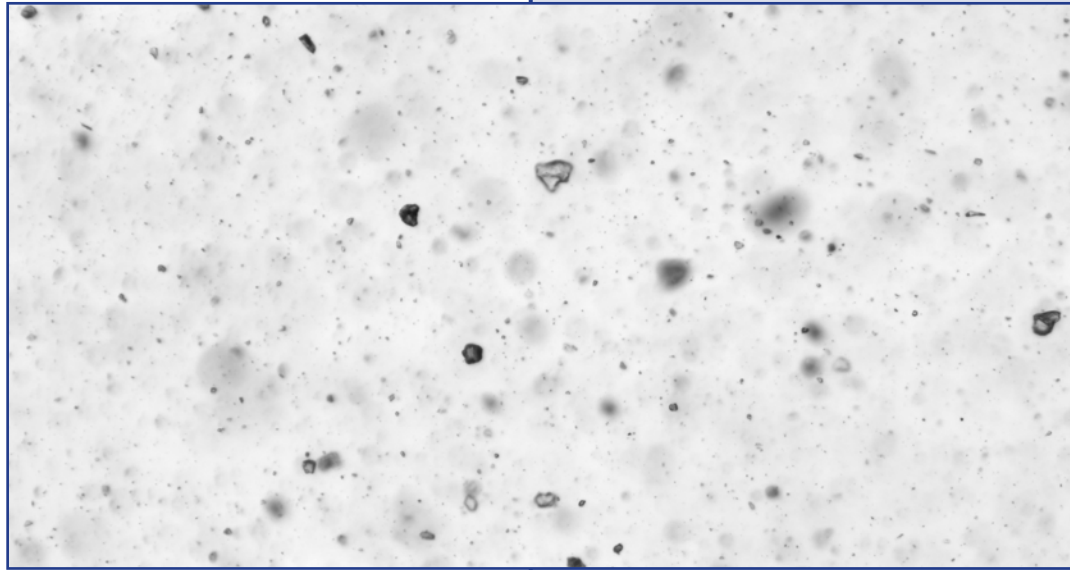

Integrating this technology inline eliminates the need for sampling, manual counting or observation to detect particles. Real-time particle detection provides a representative view of cooling water quality across the system, rather than a single point-in-time sample. This data allows operators to spot abnormal particle levels, confirm filtration performance, and determine when cleaning or flushing is necessary. Tracking particle size and concentration over time helps prevent cooling issues and protect hardware reliability.

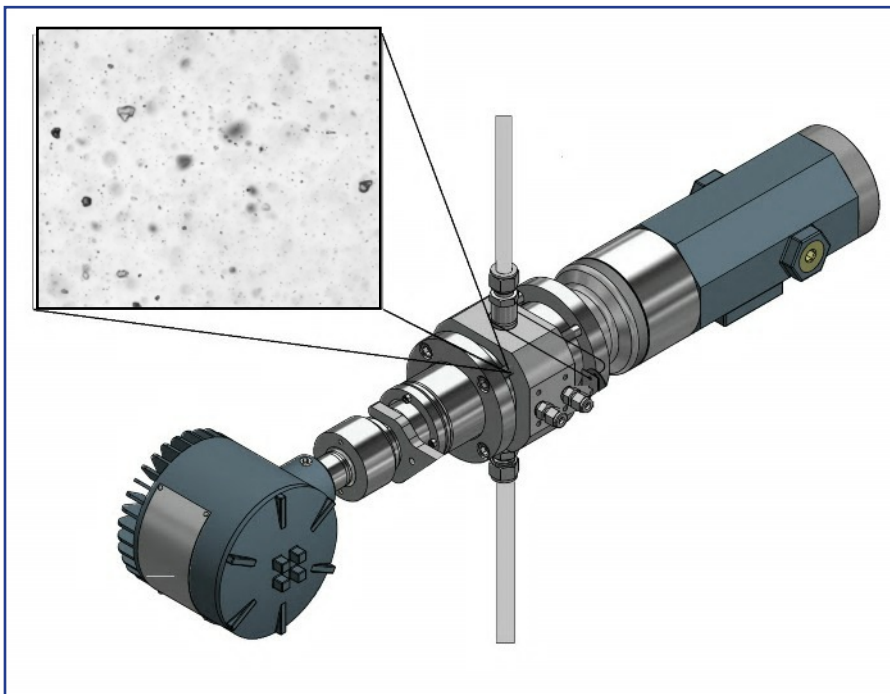

## How Dynamic Imaging Works

Dynamic imaging makes use of image analysis on a video stream of microscopic images. CANTY's InFlow™ captures images of the process fluid and potential contaminants. These images are then transmitted back to a Vector Control Module (VCM) which hosts the software that performs the analysis.

The analyzer is calibrated by installing a tool that displays a grid pattern on the camera. This grid is used to determine the physical distance that each pixel represents on the camera image, what CANTY refers to as the pixel scale factor (PSF). This is typically reported in  $\mu\text{m}/\text{pixel}$ . Knowing the PSF, the 2-dimensional area of each frame can be calculated.

The lens utilized in an InFlow™ has a known depth of field (DOF). The DOF is a measurement of the depth in which subjects, such as the particles in a fluid, are in focus. This now allows CANTY to measure the volume of each image taken in which particles are in focus.

On each image, the CantyVision software determines what might be a "particle" from what is the background fluid. At this stage, the "particle" could be anything - a solid, rouge, biofilm, or bubble. After finding something that could be a particle, the software next makes a measurement that grades whether or not the particle is in focus. If it is in focus, then this particle is within the depth of field of the lens used. That means it should be included in the analysis. If a particle is not in focus, it is disregarded.

Each type of particle, solids, and bubbles, look morphologically different from one another. These differences are captured, numerically, in the various shape factors measured. The software is trained via AI to recognize the trends in these shape factors belonging to each type of particle. This is key because it allows CANTY to distinguish between different kinds of particles that were captured in the same analysis and quantify measurements for each class of particle differently.

After a particle has been sorted into its correct class, the software calculates a volume of that particle based on its class. Since we already have the volume of each image being analyzed, the concentration of any given class of particle can now be calculated on a volumetric basis and can be converted into a mass concentration using the bulk density of the particle class in question.

By averaging over hundreds of images, the InFlow™ is able to provide a representative concentration and particle size distribution for each particle class analyzed. Additionally, if there is ever skepticism about the reading, the images from the analyzer can be viewed live and/or saved as a recording for reference.

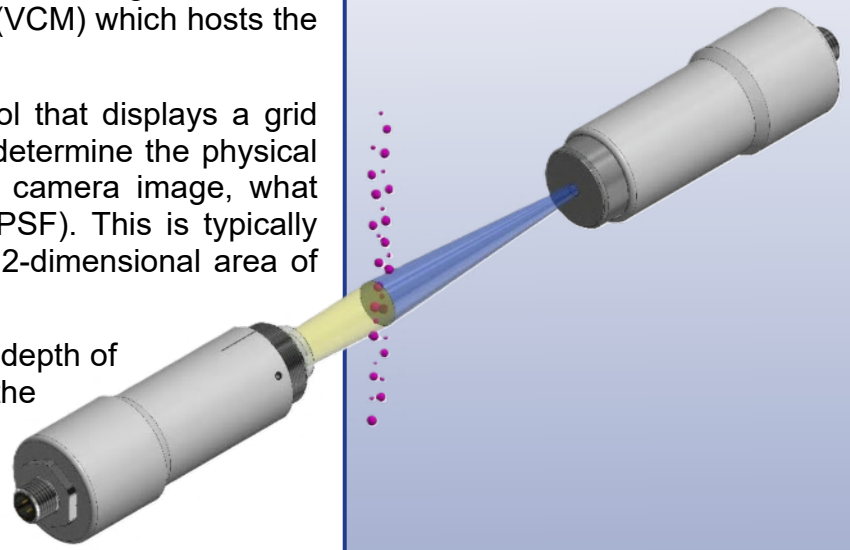

## InFlow™ Hardware

The hardware involved in CANTY's InFlow™ includes 4 main key technologies: the flow cell, lighting, camera optics, and Vector Control Module (VCM).

The flow cell on an InFlow™ is designed to mount directly inline with standard sizes up to a pipe size of 3". (Custom units may be provided for line sizes greater than 3". Consult the factory for details.) The flow cell is designed to orient particles such that the analyzer is always able to capture an image of the longest side of each particle. This is key to accurately sizing each particle seen. Critically, the flow cell seals the light and camera from the process using CANTY's fused glass technology. This fused glass barrier, unique to CANTY, can sustain extremely high temperatures and pressures while still allowing for a view into the process. Unlike other analyzers, this fusion of metal to glass creates a hermetic seal eliminating the need for gaskets or O-rings at the glass interface where the camera views and light shines through. The smooth, crevice-free viewing surface makes it difficult for contaminants to adhere or accumulate, which is extremely important for mining slurries.

CANTY says that there are three keys to a perfect image: lighting, lighting, and lighting. CANTY has been leading the industry and innovating in process lighting since the 1970's and applies all of that knowledge in the InFlow™ analyzer. The LED light used is the brightest in the industry with a guaranteed lifetime of 5 years. Unlike many other analyzers, the light in the InFlow™ back-lights the process, resulting in sharp, crisp images of each in-focus particle.

The high-resolution gigabit Ethernet CCD optics used in every InFlow™ undergo rigorous testing to ensure long-term durability and performance. Because imaging technology is always advancing, CANTY continually evaluates the latest cameras and lenses to deliver the highest-quality images without compromising the analyzer's quality and reliability. Optics used in any given analyzer are picked according to the requirements of the application. The latest generation of optics used in the InFlow™ utilize a 4K resolution camera that can pick up on particles as small as 1µm.

Obtaining a high quality image of a process is only half the battle. The magic happens when that image is processed on CANTY's VCM. The VCM platform is a series of powerful processors that host the CantyVision software. These machines are configured with the analyzers at the factory prior to shipping to make obtaining an image truly plug-and-play right out of the box. In an age of remote connections, the VCM have the ability for users to allow CANTY personnel to remotely access the unit to provide support and help troubleshoot the analyzers. These analyzers also provide the outputs to interface the data tags with a user's control system.

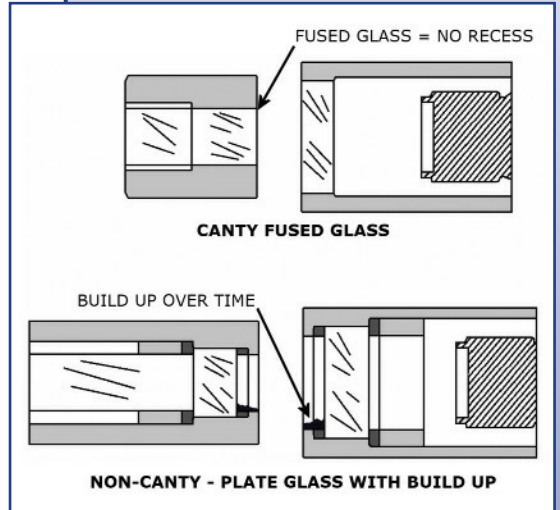

## InFlow™ Hardware Cont'd & Configurations

**CANTY InFlow™ Analyzers** can be configured multiple different ways, either in the field or in a laboratory environment. When mounted in the field the analyzer connects to two pieces of process tubing directly **inline** or **at-line** on a sample line. For either configuration vertical upward flow is preferred, flow rates and connection sizes determine if it is best to mount directly inline or on a sample line. Inline analyzer connection sizes range from 1/2" to 8" and the at-line system is a 1/2" sample line connection size.

**Inline Unit**

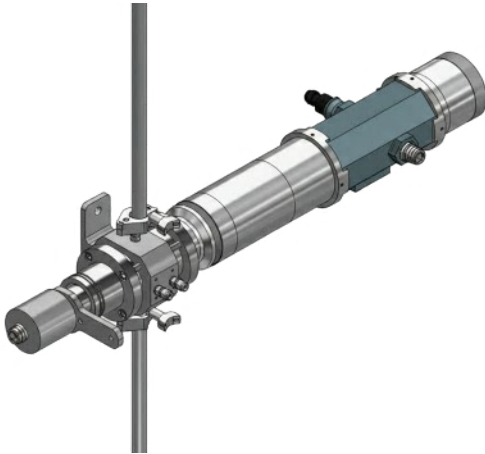

**At-Line Unit**

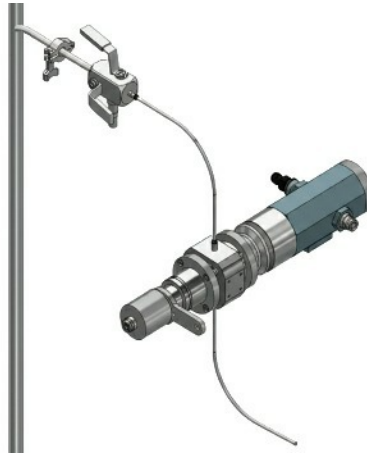

Although sampling is not recommended, these analyzers can also be configured for laboratory environments if a suitable location in the field can not be accommodated. The **Mini Lab InFlow™** can draw samples of fluid through the flow cell to analyze the sample and detect droplets, solids, rouge, or biofilm. Although sampling is not optimal, dynamic imaging is still being utilized which has many benefits above other methods such as laser light obscuration. Any lab configuration is fully automated, requiring limited operator intervention. When there are several streams that need to be tested and permanent installations on each may not be possible, the **Portable InFlow™** can be used. This system is easily moved from stream to stream to run short-term testing on each. This can also be a useful tool in situations where space is limited and monitoring is only needed occasionally.



**Mini Lab InFlow™**



**Portable InFlow™**



## Data Outputs For Particles in Cooling Water

When a particle is detected in cooling water, it is critical to capture as much information as quickly as possible. Inline dynamic imaging analyzers provide the following key outputs:

- Count of suspended solids/rouge, biofilm, and counts of bubbles per unit volume of process fluid

Combined with size data, outputs of counts/mL in a size range output to match USP 788/1788.

- Shape and Size distribution of the solid particles

The shape and size distribution of the suspended solids can give information on the type of solid and promote understanding of biological, chemical, and physical processes that form the solids.

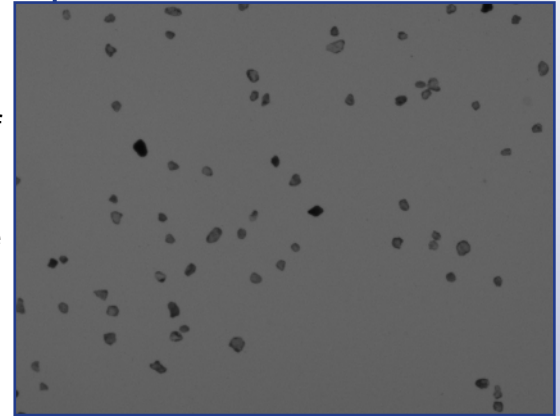

In addition to particle-specific measurements, generic system health alerts monitor analyzer status, including camera temperature, signal integrity, and communication health.

All outputs can be trended over time in a data historian to track contamination patterns, evaluate filtration performance, and assess overall cooling system health. The analyzer supports standard communication protocols—including OPC UA, Modbus TCP/IP, Modbus RTU, and Analog (4–20 mA)—to integrate seamlessly with building or process control systems.

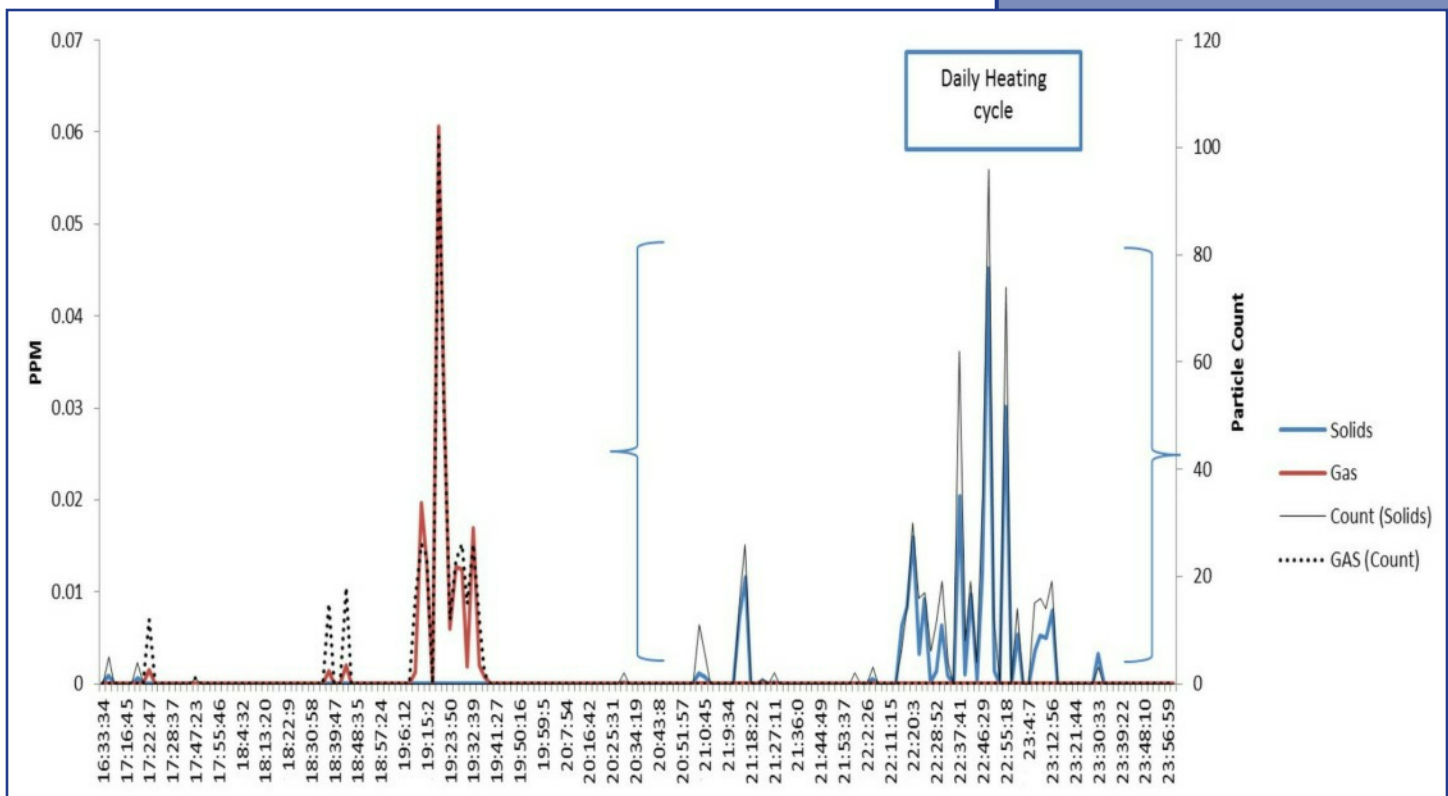

# Conclusion

CANTY's InFlow™ analyzer is an effective tool for the automatic detection and measurement of particles in data center cooling water. Installed directly inline, they avoid the limitations of sampling-based methods, can detect very small particles, and provide multiple outputs that help evaluate filtration performance and overall system water quality. The analyzer captures two-dimensional measurements while filtering out gas bubbles, resulting in more accurate and detailed data. These measurements provide a reliable way to monitor particle levels, optimize cooling system performance, and protect critical hardware from particulate-related issues.

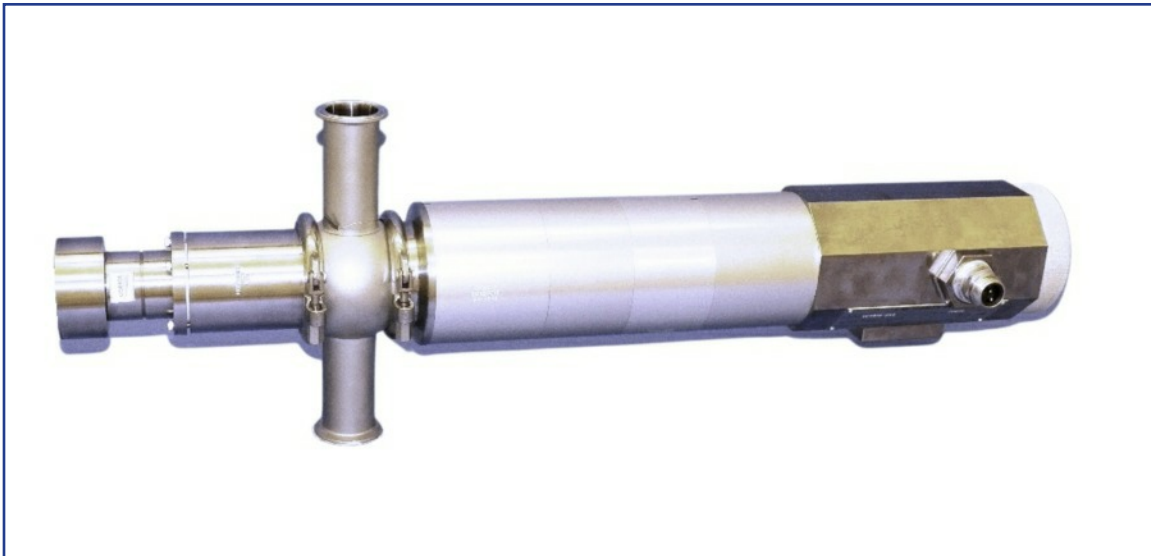

Get more information!  
Website: <https://www.jmcanty.com>

## North America

JM Canty, Inc.  
6100 Donner Road  
Buffalo, NY, United States  
+1 (716) 625-4227  
[sales@jmcanty.com](mailto:sales@jmcanty.com)  
[techsupport@jmcanty.com](mailto:techsupport@jmcanty.com)

## EU & International

JM Canty International, Ltd.  
Ballycoolin Business Park  
Blanchardstown  
Dublin 15, D15 KV02, Ireland  
+353 (1) 882-9621  
+353 (1) 882-9622  
[Sales.ie@jmcanty.com](mailto:Sales.ie@jmcanty.com)  
[Techsupport.ie@jmcanty.com](mailto:Techsupport.ie@jmcanty.com)

## Thailand Office

JM Canty Thailand Office  
Phuket, Thailand  
+66 83 9689548  
[Sales.ie@jmcanty.com](mailto:Sales.ie@jmcanty.com)  
[Techsupport.ie@jmcanty.com](mailto:Techsupport.ie@jmcanty.com)