

CANTY

PROCESS TECHNOLOGY

FUSEVIEW™ TRI-CLAMP® SIGHT GLASS

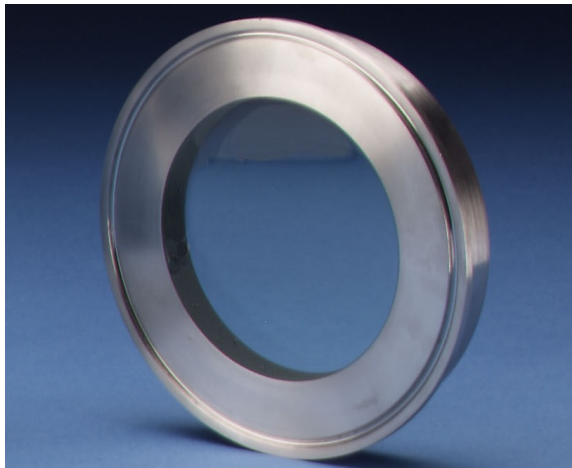

THE CANTY ADVANTAGE

Canty Fuseview™ sight glasses have been engineered to meet all your hygienic process and safety needs. Fuseview™ Tri-clamps® are a fused sight glass providing a one-piece, flush mount construction. All standard Tri-clamp® Fuseviews™ were designed and tested to ensure the safest product available. Canty can provide certification of material and testing if required, typical of ASME code requirements for process vessels. Canty Fuseview™ sight glasses are designed in strict compliance to the ASME BPE standard.

UNMATCHED SAFETY, RELIABLE

All Canty sight glasses feature the Fuseview™ window. Our unique fused glass windows far exceed all conventional tempered glass windows in safety and performance. By fusing glass to metal, a high pressure, high safety, hermetic seal is formed. The fused glass Technology ensures safety with every Fuseview™. What's more, our windows can easily be removed for cleaning. Canty windows do not have to be discarded, as do traditional tempered glass windows. They can be re-used again and again.

OPTIONS

- Lighting - Flex bundle light available to eliminate the need for a second nozzle.
- Jet spray ring - integral or two piece spray ring available for cleaning glass, see TA11500-1020.
- NA-Connect mounting options available, see datasheets TA9805-1 and TA10646-1.

FEATURES

- Stainless Steel, Alloy C, Hastelloy®C276 or equal, or Hastelloy® C-22® or equal one piece construction
- Pressure rating to 150 PSI [10 bar], actual rating is dictated by clamp and ferrule selection
- Standard temperatures to 450°F [232°C]
- One piece sanitary construction
- Connects to standard Tri-clamp® connection
- Special sizes available per drawing request
- Many, many more

ADVANTAGES OF THE FUSEVIEW™

- Extremely high strength due to radial compression on the hermetically sealed glass
- Very high impact strength and thermal shock resistance due to prestressing
- Operates under positive or negative pressure
- Certification on material and pressure rating is available, typical of ASME code requirements.

CANTY FUSEVIEW™ VS. OTHERS

- No loss of glass temper over time
- Scratches do not affect safety or life
- Unlike tempered glass, a Fuseview™ will not blow out if the surface is damaged
- No extra gaskets, shims, packing, or retaining rings to worry about

CANTY

JM Canty Inc
JM Canty Intl Ltd

Buffalo, NY USA
Dublin, Ireland

Ph: (716) 625 4227
Ph: + 353 (01) 882 9621

Fax: (716) 625 4228
Fax: +353 (01) 882 9622

www.jmcanty.com

Document P/N: TA7653-1 Rev 15

All registered trademarks are the property of their respective owners.

FUSEVIEW™ TRI-CLAMP® SPECIFICATIONS

SIZE	F	G	H	TEMP RATING
1" / 1.5" / 40mm	.94" [23.9mm]	1.98" [50.3mm]	.68" [17.3mm]	450°F [232°C]
2" / 50mm	1.18" [30mm]	2.52" [64mm]	.68" [17.3mm]	450°F [232°C]
2.5"	1.50" [38.1mm]	3.05" [77.5mm]	.68" [17.3mm]	450°F [232°C]
3" / 65mm	2.00" [50.8mm]	3.58" [90.9mm]	.68" [17.3mm]	450°F [232°C]
3.5" / 80mm	2.50" [63.5mm]	4.17" [106mm]	.68" [17.3mm]	450°F [232°C]
4" / 100mm	3.00" [76.2mm]	4.69" [119.1mm]	.68" [17.3mm]	450°F [232°C]
6"	4.00" [101.6mm]	6.57" [166.9mm]	.68" [17.3mm]	450°F [232°C]
8"	5.70" [144.8mm]	8.57" [217.7mm]	.68" [17.3mm]	450°F [232°C]

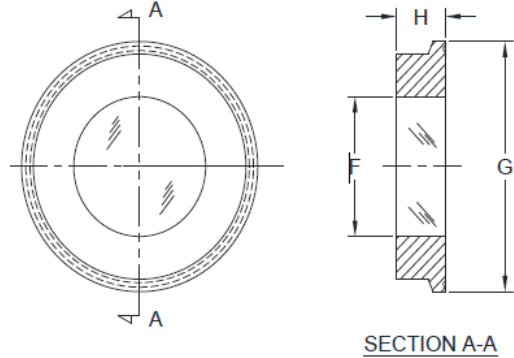

Ordering Information

HOW TO ORDER: Select the appropriate options and build a part number as shown:

EXAMPLE:

S _ A _ _ 1 _ 0A0

<table border="1" style="width: 100%; border-collapse: collapse;"> <thead> <tr style="background-color: #d9e1f2;"> <th>MODEL</th> </tr> </thead> <tbody> <tr> <td>4 - Fuseview™ Tri-Clamp®</td> </tr> <tr> <td>A - Flex Mount Tri With Tapped Holes and Brackets</td> </tr> <tr> <td>B - Flex Mount Tri With Tapped Holes</td> </tr> </tbody> </table> <table border="1" style="width: 100%; border-collapse: collapse;"> <thead> <tr style="background-color: #d9e1f2;"> <th>SIZE</th> </tr> </thead> <tbody> <tr> <td>8 - 1" / 1.5" / 25mm / 32mm / 40mm</td> </tr> <tr> <td>9 - 2" / 50mm</td> </tr> <tr> <td>A - 2.5"</td> </tr> <tr> <td>B - 3" / 65mm</td> </tr> <tr> <td>F - 3.5" / 80mm</td> </tr> <tr> <td>C - 4" / 100mm</td> </tr> <tr> <td>D - 6"</td> </tr> <tr> <td>E - 8"</td> </tr> <tr> <td>H - 150mm</td> </tr> <tr> <td>J - 200mm</td> </tr> <tr> <td>K - 250mm</td> </tr> </tbody> </table>	MODEL	4 - Fuseview™ Tri-Clamp®	A - Flex Mount Tri With Tapped Holes and Brackets	B - Flex Mount Tri With Tapped Holes	SIZE	8 - 1" / 1.5" / 25mm / 32mm / 40mm	9 - 2" / 50mm	A - 2.5"	B - 3" / 65mm	F - 3.5" / 80mm	C - 4" / 100mm	D - 6"	E - 8"	H - 150mm	J - 200mm	K - 250mm	<table border="1" style="width: 100%; border-collapse: collapse;"> <thead> <tr style="background-color: #d9e1f2;"> <th>FINISH (WETTED)</th> </tr> </thead> <tbody> <tr> <td>0 - 20 μin [.51 μm] Ra (standard)(BPE-SF1)</td> </tr> <tr> <td>C - 15 μin [.38 μm] Ra</td> </tr> <tr> <td>L - 20 μin [.51 μm] Ra Electropolished (BPE-SF5)</td> </tr> <tr> <td>M - 15 μin [.38 μm] Ra Electropolished (BPE-SF4)</td> </tr> </tbody> </table> <p style="text-align: right; font-size: 8pt;">*non-wetted = 32 μin [.81 μm] Ra</p> <table border="1" style="width: 100%; border-collapse: collapse;"> <thead> <tr style="background-color: #d9e1f2;"> <th>MATERIAL (WETTED)</th> </tr> </thead> <tbody> <tr> <td>B - 316L Stainless Steel*</td> </tr> <tr> <td>C - Alloy C</td> </tr> <tr> <td>D - Hastelloy® C276 or equal</td> </tr> <tr> <td>E - Hastelloy® C-22® or equal</td> </tr> </tbody> </table> <p style="font-size: 8pt;">*Canty reserves the right to upgrade to Hastelloy® C-family of alloys or equal at their own cost.</p>	FINISH (WETTED)	0 - 20 μin [.51 μm] Ra (standard)(BPE-SF1)	C - 15 μin [.38 μm] Ra	L - 20 μin [.51 μm] Ra Electropolished (BPE-SF5)	M - 15 μin [.38 μm] Ra Electropolished (BPE-SF4)	MATERIAL (WETTED)	B - 316L Stainless Steel*	C - Alloy C	D - Hastelloy® C276 or equal	E - Hastelloy® C-22® or equal
MODEL																											
4 - Fuseview™ Tri-Clamp®																											
A - Flex Mount Tri With Tapped Holes and Brackets																											
B - Flex Mount Tri With Tapped Holes																											
SIZE																											
8 - 1" / 1.5" / 25mm / 32mm / 40mm																											
9 - 2" / 50mm																											
A - 2.5"																											
B - 3" / 65mm																											
F - 3.5" / 80mm																											
C - 4" / 100mm																											
D - 6"																											
E - 8"																											
H - 150mm																											
J - 200mm																											
K - 250mm																											
FINISH (WETTED)																											
0 - 20 μin [.51 μm] Ra (standard)(BPE-SF1)																											
C - 15 μin [.38 μm] Ra																											
L - 20 μin [.51 μm] Ra Electropolished (BPE-SF5)																											
M - 15 μin [.38 μm] Ra Electropolished (BPE-SF4)																											
MATERIAL (WETTED)																											
B - 316L Stainless Steel*																											
C - Alloy C																											
D - Hastelloy® C276 or equal																											
E - Hastelloy® C-22® or equal																											

Please note, specification sheet TA11500-1072 is available upon request.